

Stamped Fittings® - Product Specifications

High Efficiency Take-Off (HET)

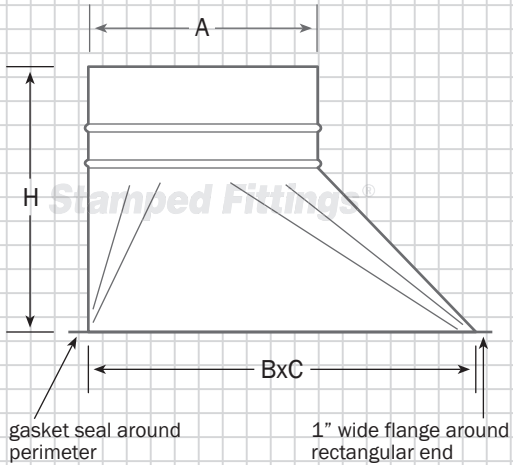

High Efficiency Take-Off (HETD)

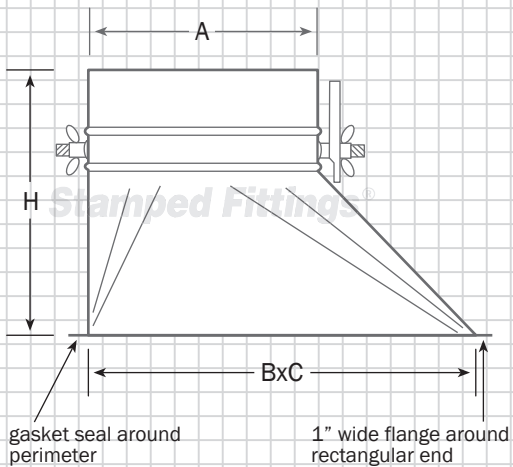

OPTION: 2" Shaft Extension Handle (HETD2S)

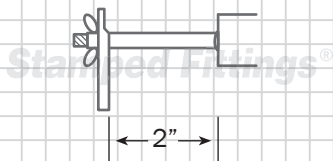

Key

A = Diameter
 BxC = Base
 H = Height
 HET - No damper
 HETD - With damper

Construction

- Togglelock seam

Materials Available

- Galvanized, 26 ga.
- Complete with peel & stick neoprene gasket

Options Available

- 2" Stand-off, HETD2S (see shaft extension handle drawing to the left)

Dimensions

(A)	(BxC)	(H)	26 Ga. Weight
4"	10"x5"	9-1/4"	1.04#
5"	10"x5"	9-1/2"	1.60#
6"	12"x6"	9-1/4"	1.80#
7"	12"x6"	9-1/4"	2.00#
8"	12"x6"	9-1/4"	2.20#
9"	15"x6"	10-1/2"	2.80#
10"	16"x6-3/4"	10-1/4"	3.00#
12"	18"x8-1/2"	10-1/4"	3.60#
14"	20"x9-1/2"	10-1/2"	4.20#
16"	22"x14"	13"	6.60#