

***Stamped Fittings***  
LLC

**Stamped**

***HVAC Spiral Pipe  
Component Parts***

## Yellow label union manufacturer of round HVAC Spiral Pipe components

Stamped Fittings® HVAC components will save you time and money on your next spiral pipe job. In a market that is becoming more and more competitive, cutting costs is crucial. We have what you need to compete in the market. Our extensive inventory of pre-boxed fittings are readily available to make your job faster, easier and cost effective.

We continue our commitment to provide quality products as well as prompt, courteous service. Please feel free to contact us if you have any questions or would like pricing and samples.

### CONSTRUCTION STANDARD

All fittings are made per SMACNA's Duct Construction Standards (-2" W.G. / +10" W.G.).

**It's Fast, It's Easy, It's Stamped Fittings®**

## Stamped Fittings® – Product Line

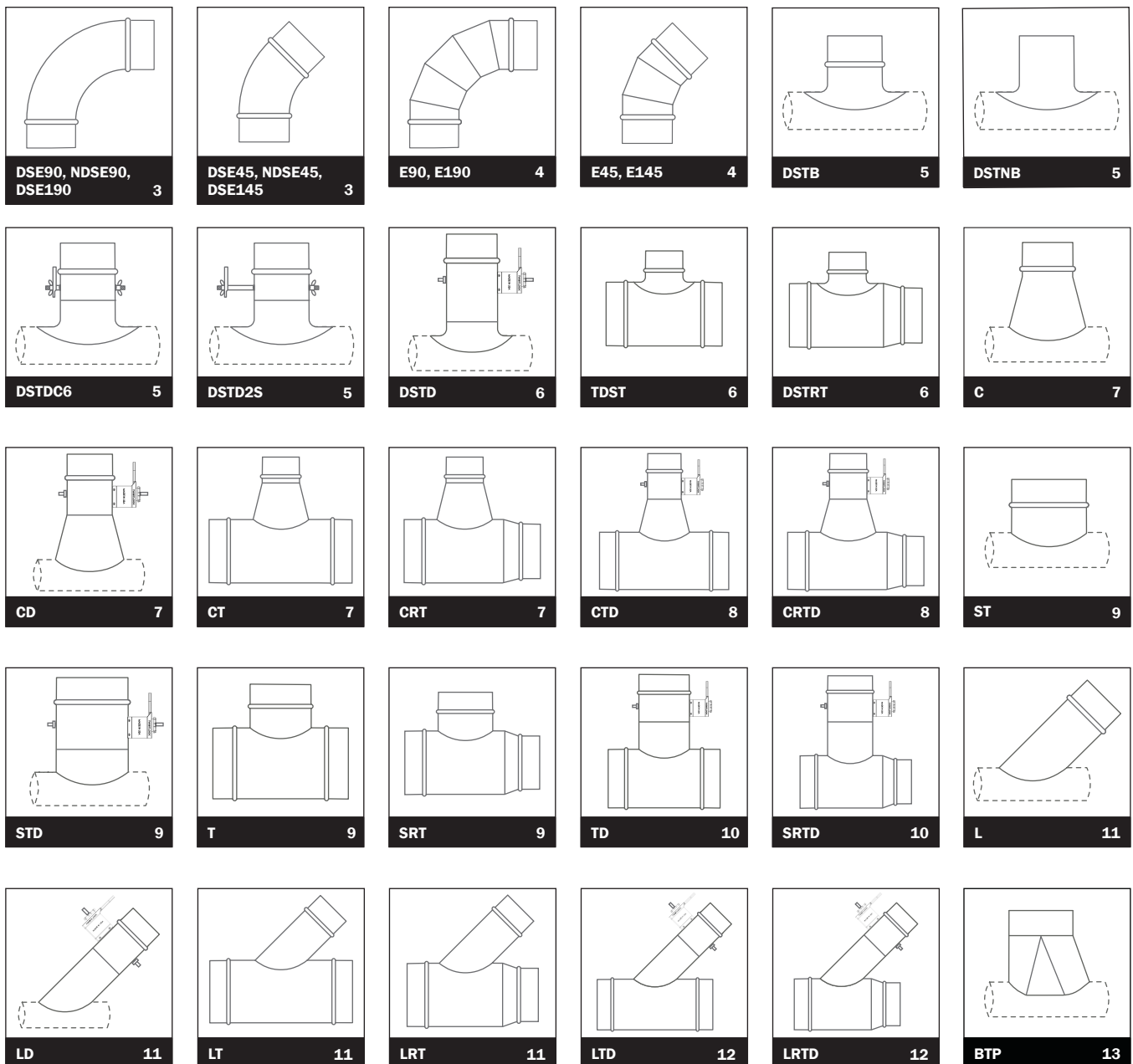

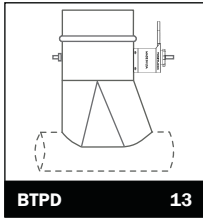

**BTPD** 13

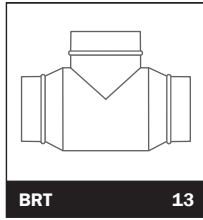

**BRT** 13

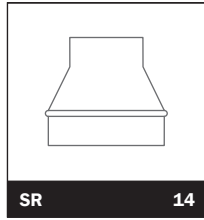

**SR** 14

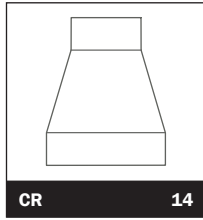

**CR** 14

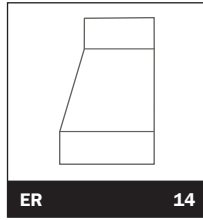

**ER** 14

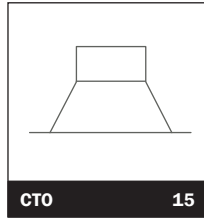

**CTO** 15

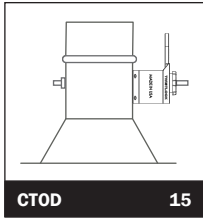

**CTOD** 15

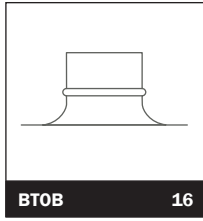

**BTOB** 16

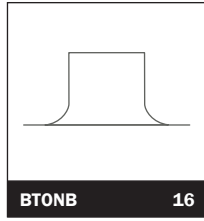

**BTONB** 16

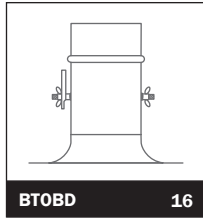

**BTOBD** 16

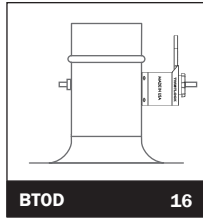

**BTOD** 16

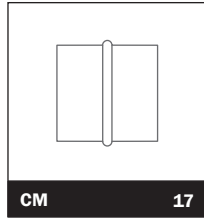

**CM** 17

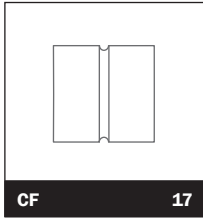

**CF** 17

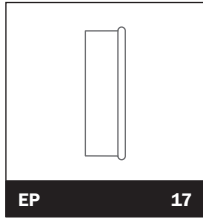

**EP** 17

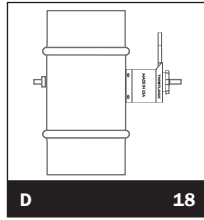

**D** 18

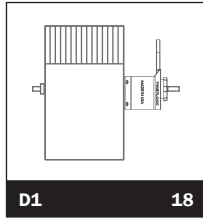

**D1** 18

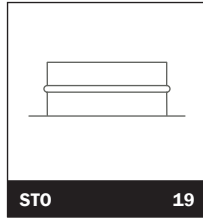

**STO** 19

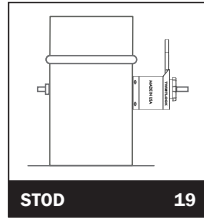

**STOD** 19

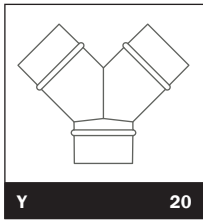

**Y** 20

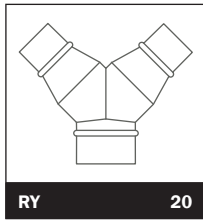

**RY** 20

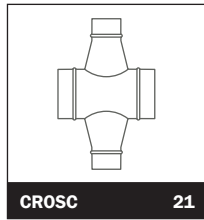

**CROSC** 21

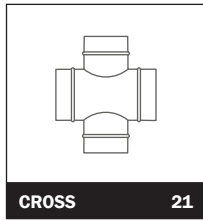

**CROSS** 21

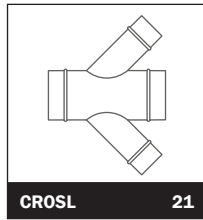

**CROSL** 21

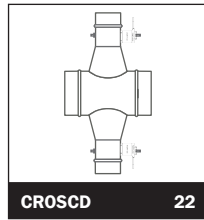

**CROSCD** 22

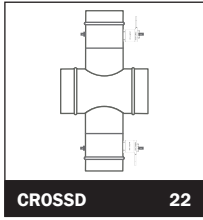

**CROSSD** 22

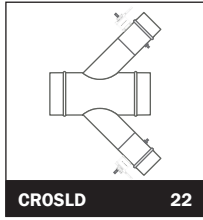

**CROSLD** 22

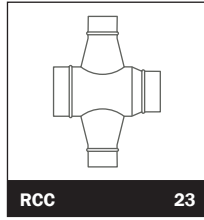

**RCC** 23

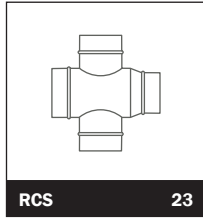

**RCS** 23

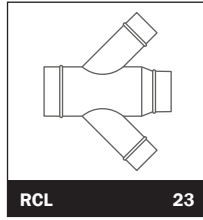

**RCL** 23

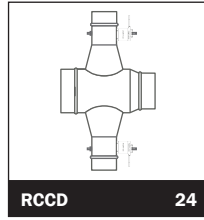

**RCCD** 24

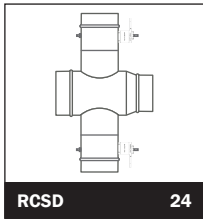

**RCSD** 24

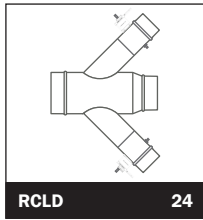

**RCLD** 24

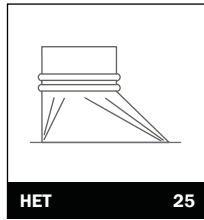

**HET** 25

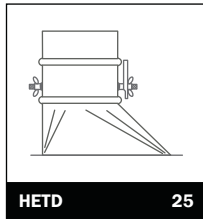

**HETD** 25

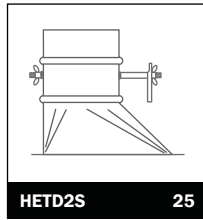

**HETD2S** 25

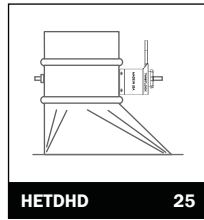

**HETDHD** 25

**90° Die Stamped 1.5 CLR Elbow  
Galvanized (DSE90)  
Galvaneal (NDSE90)**

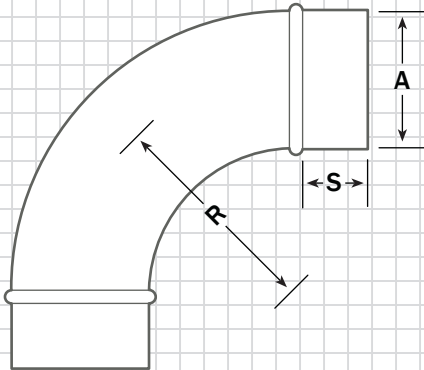

**90° Die Stamped 1.0 CLR Elbow  
Galvanized (DSE190)**

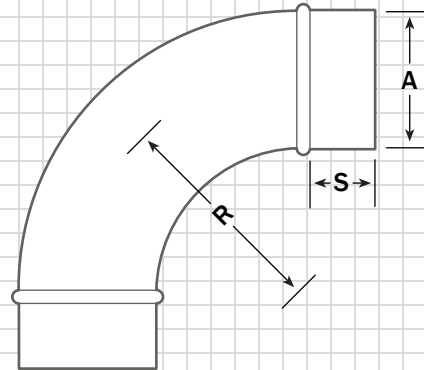

**45° Die Stamped 1.5 CLR Elbow  
Galvanized (DSE45)  
Galvaneal (NDSE45)**

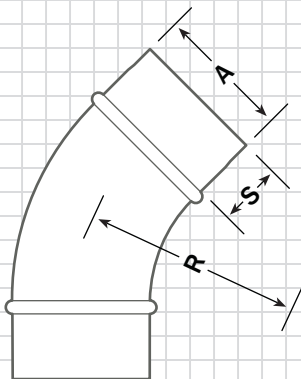

**45° Die Stamped 1.0 CLR Elbow  
Galvanized (DSE145)**

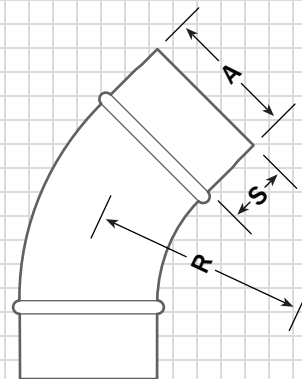

**Key**

A = 4" - 10" (all sizes), 12"  
R = 1.1/2 A (centerline radius)  
S = 2"

**Key**

A = 4" - 8" (all sizes), 10"  
R = 1A (centerline radius)  
S = 2"

**Gauge**

DSE Gauges: 3" - 6" = 24 ga.; 7" - 12" = 22 ga.  
DSE1 Gauges: 4" - 10" = 24 ga.  
NDSE Gauges: 4" - 12" = 22 ga.

**90° Elbow**  
**1.5 CLR (E90)**  
**1.0 CLR (E190)**

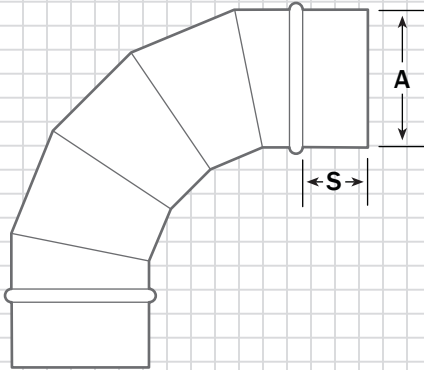

**Key**

A = 4" - 10" (all sizes), 12" - 60" (even sizes only)  
 S = 2"

- Specify CLR (1.5, 1.0, etc.)
- Specify Degree (15°, 22.5°, 30°, 45°, 60°, 90°, etc.)
- Up to 30° = 2 Piece
- 30° + up to but not including 60° = 3 Piece
- 60° + up to but not including 90° = 4 Piece
- 90° (1.5 CLR) = 5 Piece
- 90° (1.0 CLR) = 4 Piece

**Gauge**

12" - 24" = 24 ga.  
 26" - 36" = 22 ga.

**45° Elbow**  
**1.5 CLR (E45)**  
**1.0 CLR (E145)**

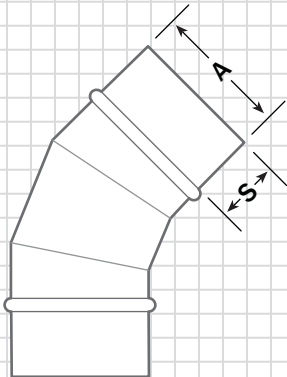

**90° Die Stamped Saddle Tap  
Bead (DSTB)  
No Bead (DSTNB)**

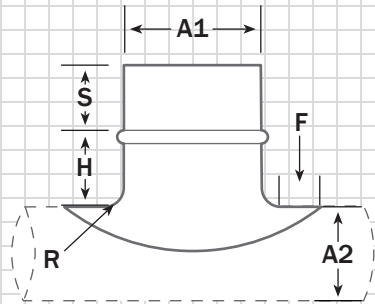

**90° Die Stamped Saddle Tap with  
Damper (DSTDC6 / DSTD2S)**

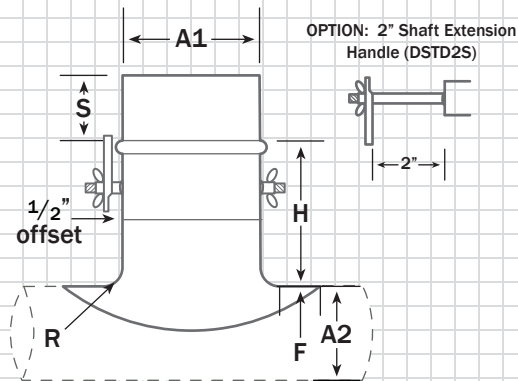

**Dimensions**

A1	A2	S (DSTB, DSTNB)	S (DSTDC6, DSTD2S, DSTD)	R	F	H (DSTB, DSTNB)	H (DSTDC6, DSTD2S, DSTD)
4"	4"	1.125"	2"	0.787"	1"	1"	5.75"
4"	5"	1.125"	2"	0.787"	1"	1"	5.75"
4"	6" - 7"	1.125"	2"	0.787"	1"	1"	5.75"
4"	8"	1.125"	2"	0.787"	1"	1"	5.75"
4"	9" - 10"	1.125"	2"	0.787"	1"	1"	5.75"
4"	12" - 14"	1.125"	2"	0.787"	1"	1"	5.75"
4"	16" - 24"	1.125"	2"	0.787"	1"	1"	5.75"
5"	5"	1.25"	2"	0.787"	1"	1"	5.625"
5"	6" - 7"	1.25"	2"	0.787"	1"	1"	5.625"
5"	8" - 9"	1.25"	2"	0.787"	1"	1"	5.625"
5"	10"	1.25"	2"	0.787"	1"	1"	5.625"
5"	12" - 14"	1.25"	2"	0.787"	1"	1"	5.625"
5"	16" - 24"	1.25"	2"	0.787"	1"	1"	5.625"
6"	6"	1.5"	2"	0.787"	1"	1.125"	6.125"
6"	8"	1.5"	2"	0.787"	1"	1.75"	6.75"
6"	10" - 12"	1.5"	2"	0.787"	1"	1.75"	6.75"
6"	14" - 18"	1.5"	2"	0.787"	1"	1.75"	6.75"
6"	20" - 24"	1.5"	2"	0.787"	1"	1.75"	6.75"
8"	8"	1.5"	2"	1"	1"	1"	6"
8"	10"	1.5"	2"	1"	1"	1.75"	6.75"
8"	12" - 14"	1.5"	2"	1"	1"	1.75"	6.75"
8"	16" - 18"	1.5"	2"	1"	1"	1.75"	6.75"
8"	20" - 24"	1.5"	2"	1"	1"	1.75"	6.75"
10"	10"	1.5"	2"	1"	2"	1.125"	6.125"
10"	12"	1.5"	2"	1"	2"	2"	6.75"
10"	14" - 16"	1.5"	2"	1"	2"	2"	6.75"
10"	18" - 20"	1.5"	2"	1"	2"	2"	6.75"
10"	22" - 24"	1.5"	2"	1"	2"	2"	6.75"
12"	12"	1.5"	2"	1"	2"	1.125"	6.25"
12"	14" - 16"	1.5"	2"	1"	2"	2"	6.75"
12"	18" - 20"	1.5"	2"	1"	2"	2"	6.75"
12"	22" - 24"	1.5"	2"	1"	2"	2"	6.75"

**Key**

A1 = Branch (nominal) size      H = Height  
 A2 = Pipe (nominal) size      R = Radius  
 F = Flange on pipe

**Options Available**

- 2" Stand-offs, DSTD26 (see shaft extension handle drawing above)

**Gauge**

- Galvanized, 24 ga.

**90° Die Stamped Saddle Tap with Damper (DSTD)**

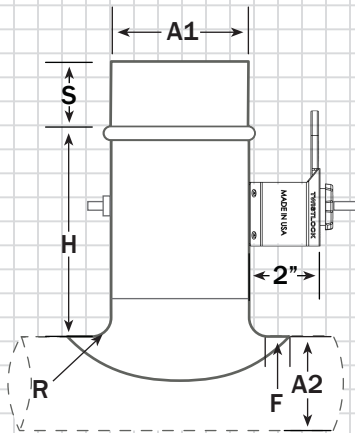

**90° Tee with Die Stamped Saddle Tap (TDST)**

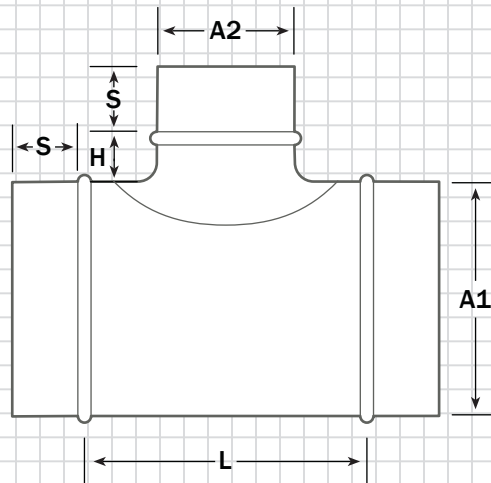

**Low-Leakage Dampers:**

- 2" Stand-off
- Nylon bushings
- Locking handle
- 3/8" Continuous square rod
- All dampers to be installed 90° from the inlet of airflow

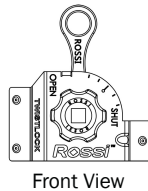

**90° Reducing Tee with Die Stamped Saddle Tap (DSTRT)**

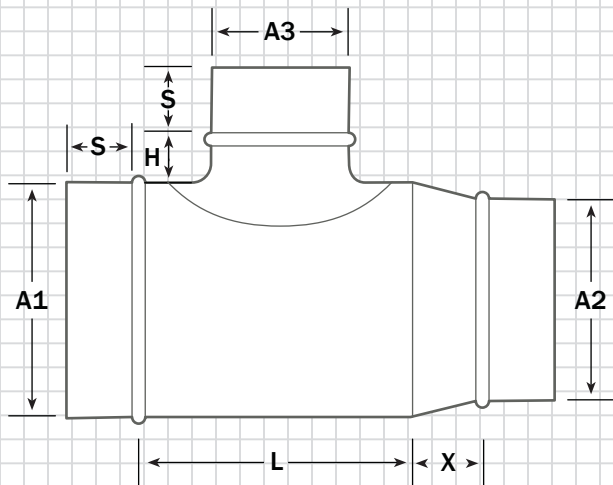

**Key (DSTD)**

A1 = 4", 5", 6", 8", 10", 12"  
 A2 = Up to 24" (A2 is greater than or equal to A1)

**Key (TDST)**

A1 = Up to 24" (A1 is greater than or equal to A2)  
 A2 = 4", 5", 6", 8", 10", 12"  
 L = A2 + 4"

**Key (DSTRT)**

A1 = Up to 24" (A1 is greater than or equal to A2)  
 A2 = Up to 24" (A2 is less than A1)  
 A3 = 4", 5", 6", 8", 10", 12"  
 L = A3 + 4"  
 X = A1 - A2 (4" minimum)

**Additional Data**

See chart on Page 5 for all additional data.

**Gauge**

- Galvanized, 24 ga.

**90° Conical (C)**

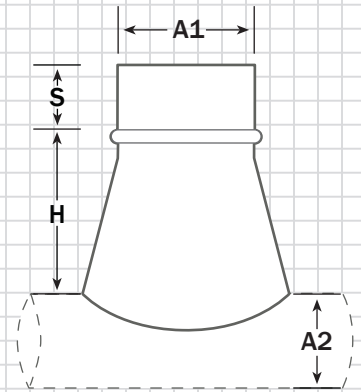

**90° Conical with Damper (CD)**

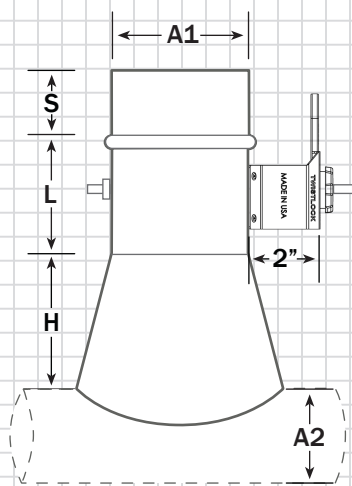

**90° Conical Tee (CT)**

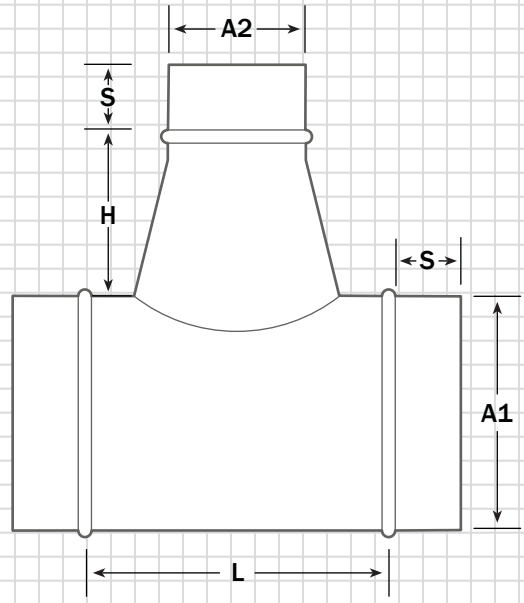

**Key (C)**

**Sizes Available for A1:**  
 4" - 10" (all sizes), 12" - 60" (even sizes only)  
 A2 is greater than A1  
 S = 2"  
 H = 5"

**Key (CD)**

**Sizes Available for A1:**  
 4" - 10" (all sizes), 12" - 60" (even sizes only)  
 A2 is greater than A1  
 S = 2"  
 H = 5"  
 L = 3.5"

**Key (CT)**

**Sizes Available for A1 & A2:**  
 4" - 10" (all sizes), 12" - 60" (even sizes only)  
 A1 is greater than A2  
 S = 2"  
 H = 5"  
 L = A2 + 4"

**Key (CRT)**

**Sizes Available for A1, A2 & A3:**  
 4" - 10" (all sizes), 12" - 60" (even sizes only)  
 A1 is greater than A3, A2 is less than A1  
 S = 2"  
 H = 5"  
 L = A3 + 4"  
 X = A1 - A2 (4" minimum)

**Gauge**

4" - 24" = 24 ga.  
 26" - 36" = 22 ga.

**90° Conical Reducing Tee (CRT)**

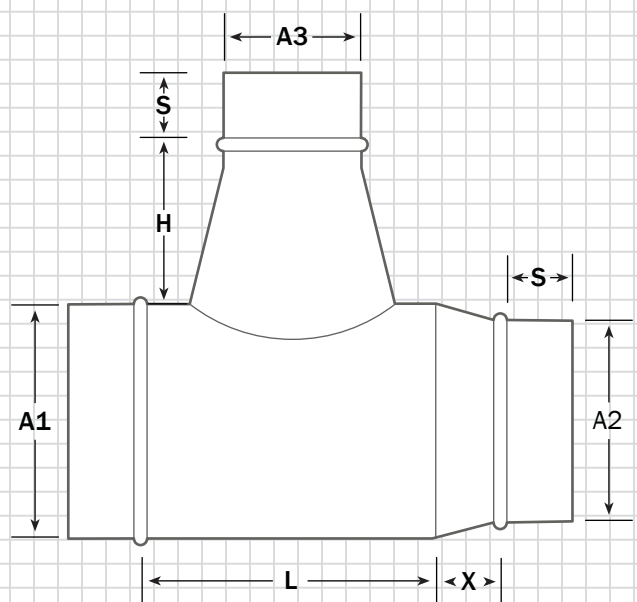

**Low-Leakage Dampers:**

- 2" Stand-off
- Nylon bushings
- Locking handle
- 3/8" Continuous square rod
- All dampers to be installed 90° from the inlet of airflow

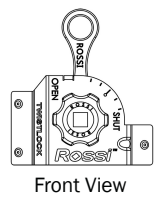

**90° Conical Tee with Damper (CTD)**

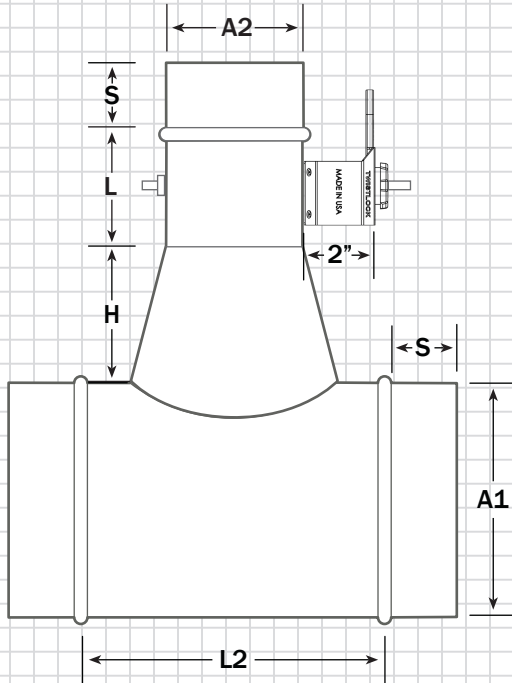

**Key (CTD)**

Sizes Available for A1 & A2:  
 4" - 10" (all sizes), 12" - 60" (even sizes only)  
 A1 is greater than A2  
 S = 2"  
 H = 5"  
 L = 3.5"  
 L2 = A2 + 4"

**Key (CRTD)**

Sizes Available for A1, A2 & A3:  
 4" - 10" (all sizes), 12" - 60" (even sizes only)  
 A1 is greater than A3, A2 is less than A1  
 S = 2"  
 H = 5"  
 L = 3.5"  
 L2 = A3 + 4"  
 X = A1 - A2 (4" minimum)

**Gauge**

4" - 24" = 24 ga.  
 26" - 36" = 22 ga.

**Low-Leakage Dampers:**

- 2" Stand-off
- Nylon bushings
- Locking handle
- 3/8" Continuous square rod
- All dampers to be installed 90° from the inlet of airflow

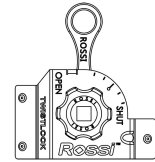

Front View

**90° Conical Reducing Tee with Damper (CRTD)**

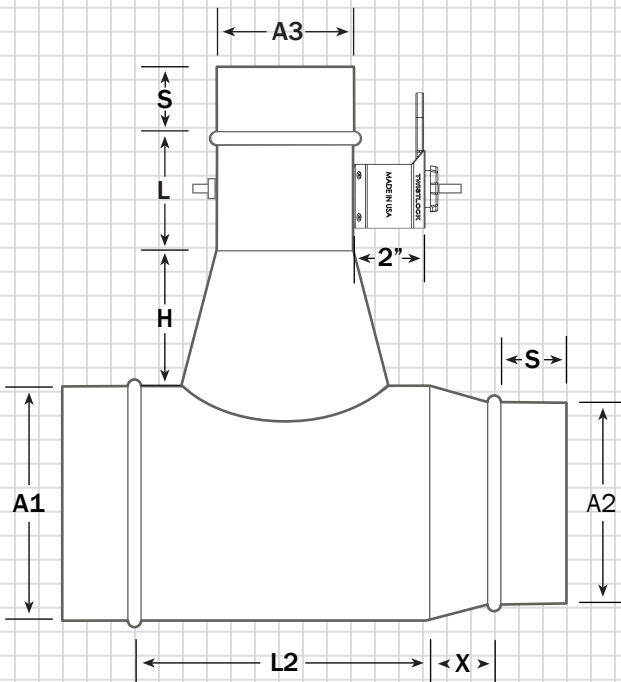

### Straight Tap (ST)

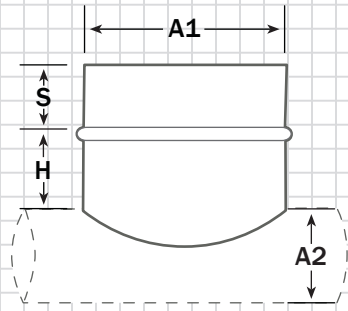

### 90° Straight Tap with Damper (STD)

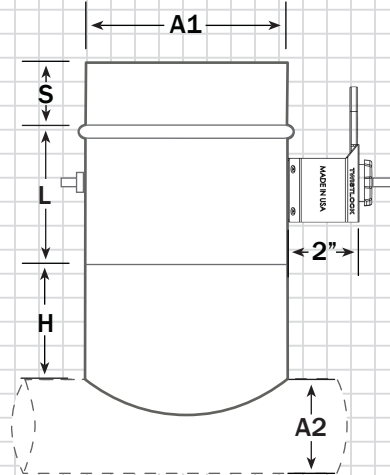

### 90° Tee (T)

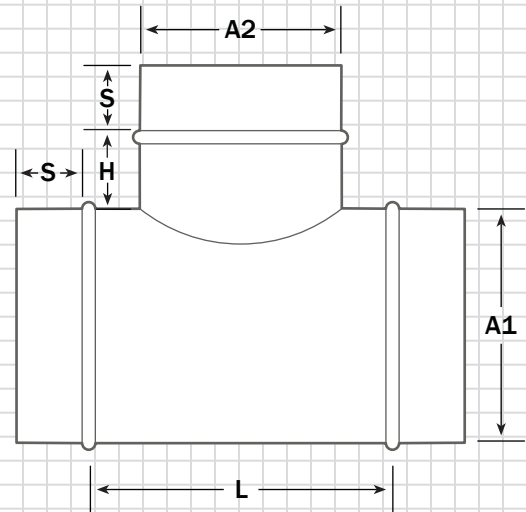

#### Key (ST)

**Sizes Available for A1:**  
 4"- 10" (all sizes), 12"- 60" (even sizes only)  
**A2** is greater than or equal to **A1**  
**S** = 2"  
**H** = 2"

#### Key (STD)

**Sizes Available for A1:**  
 4"- 10" (all sizes), 12"- 60" (even sizes only)  
**A2** is greater than **A1**  
**S** = 2"  
**H** = 4"  
**L** = 3.5"

#### Key (T)

**Sizes Available for A1 & A2:**  
 4"- 10" (all sizes), 12"- 60" (even sizes only)  
**A1** is greater than or equal to **A2**  
**S** = 2"  
**H** = 2"  
**L** =  $A2 + 4$ "

#### Key (SRT)

**Sizes Available for A1, A2 & A3:**  
 4"- 10" (all sizes), 12"- 60" (even sizes only)  
**A1** is greater than **A3**, **A2** is less than **A1**  
**S** = 2"  
**H** = 2"  
**L** =  $A3 + 4$ "  
**X** =  $A1 - A2$  (4" minimum)

#### Gauge

4"- 24" = 24 ga.  
 26"- 36" = 22 ga.

### 90° Straight Reducing Tee (SRT)

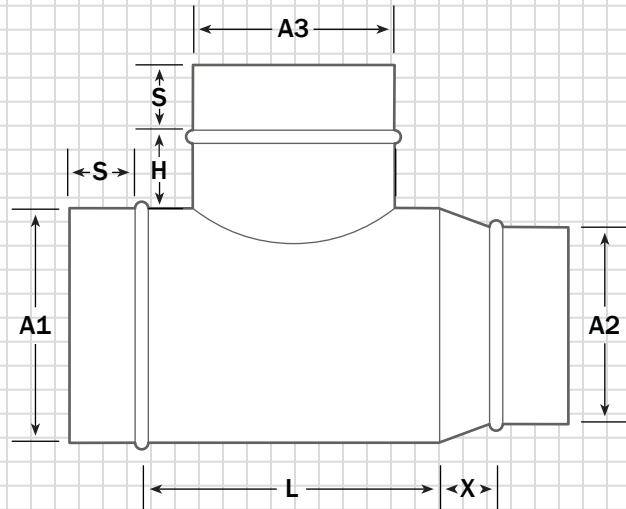

#### Low-Leakage Dampers:

- 2" Stand-off
- Nylon bushings
- Locking handle
- 3/8" Continuous square rod
- All dampers to be installed 90° from the inlet of airflow

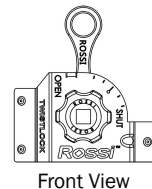

**90° Tee with Damper (TD)**

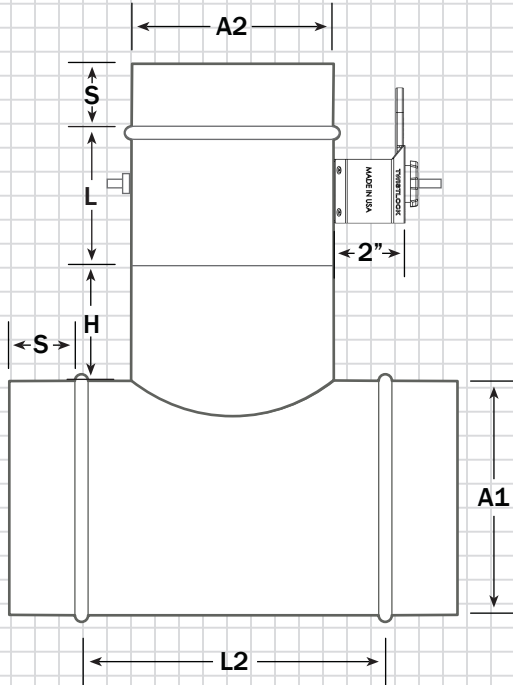

**Key (TD)**

**Sizes Available for A1 & A2:**  
 4" - 10" (all sizes), 12" - 60" (even sizes only)  
**A1 is greater than or equal to A2**  
 S = 2"  
 H = 4"  
 L = 3.5"  
 L2 = A2 + 4"

**Key (SRTD)**

**Sizes Available for A1, A2 & A3:**  
 4" - 10" (all sizes), 12" - 60" (even sizes only)  
**A1 is greater than A3, A2 is less than A1**  
 S = 2"  
 H = 4"  
 L = 3.5"  
 L2 = A3 + 4"  
 X = A1 - A2 (4" minimum)

**Gauge**

4" - 24" = 24 ga.  
 26" - 36" = 22 ga.

**90° Straight Reducing Tee with Damper (SRTD)**

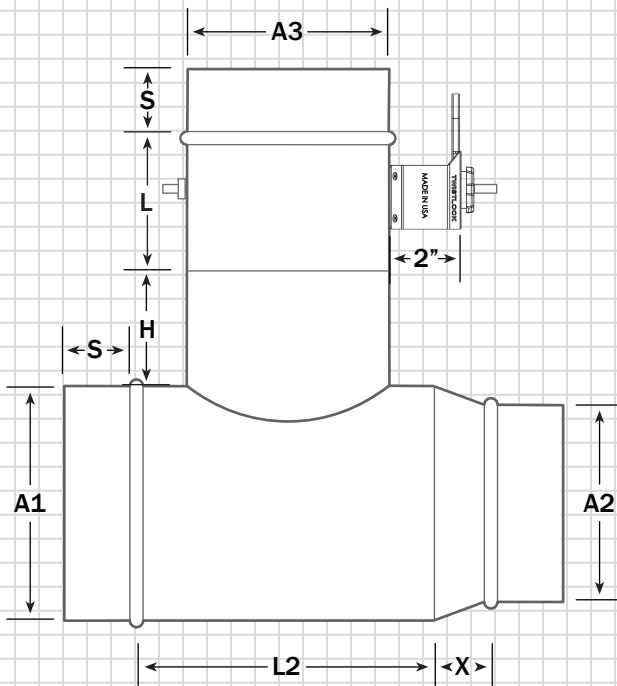

**Low-Leakage Dampers:**

- 2" Stand-off
- Nylon bushings
- Locking handle
- 3/8" Continuous square rod
- All dampers to be installed 90° from the inlet of airflow

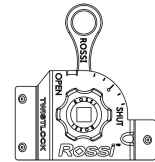

Front View

**45° Lateral (L)**

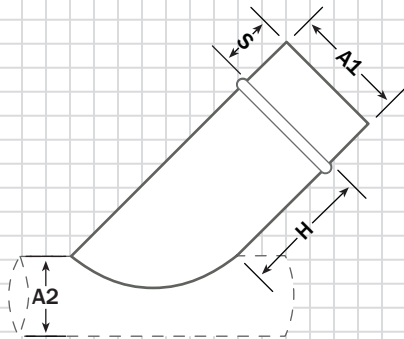

**45° Lateral with Damper (LD)**

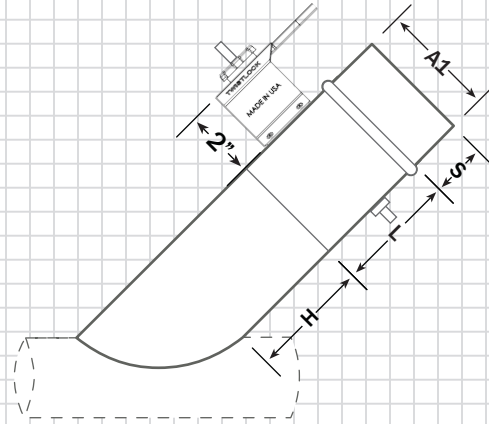

**45° Lateral Tee (LT)**

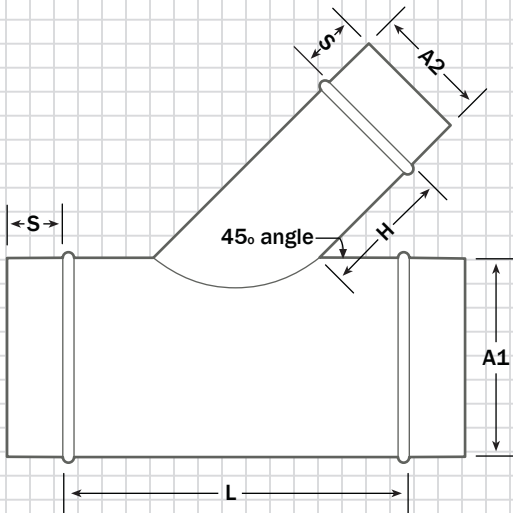

**45° Lateral Reducing Tee (LRT)**

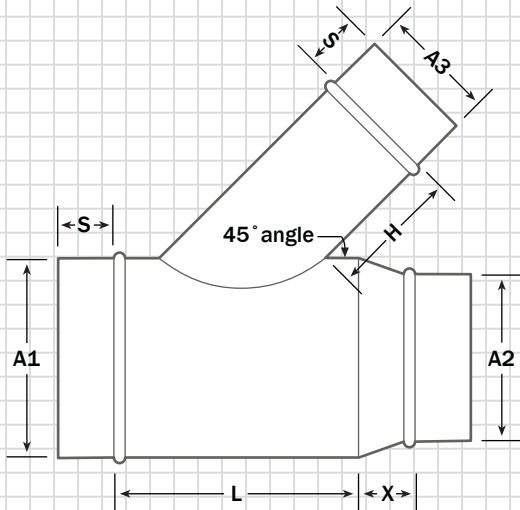

**Key (L)**

**Sizes Available for A1:**  
 4" - 10" (all sizes), 12" - 60" (even sizes only)  
**A2 is greater than A1**  
 S = 2"  
 H = 4"

**Key (LD)**

**Sizes Available for A1:**  
 4" - 10" (all sizes), 12" - 60" (even sizes only)  
**A2 is greater than or equal to A1**  
 S = 2"  
 H = 4"  
 L = 3.5"

**Key (LT)**

**Sizes Available for A1 & A2:**  
 4" - 10" (all sizes), 12" - 60" (even sizes only)  
**A1 is greater than or equal to A2**  
 S = 2"  
 H = 4"  
 L = (A2 x 1.414) + 4"

**Key (LRT)**

**Sizes Available for A1, A2 & A3:**  
 4" - 10" (all sizes), 12" - 60" (even sizes only)  
**A1 is greater than or equal to A3**  
**A2 is less than A1**  
 S = 2"  
 H = 4"  
 L = (A3 x 1.414) + 4"  
 X = A1 - A2 (4" minimum)

**Gauge**

4" - 24" = 24 ga.  
 26" - 36" = 22 ga.

**Low-Leakage Dampers:**

- 2" Stand-off
- Nylon bushings
- Locking handle
- 3/8" Continuous square rod
- All dampers to be installed 90° from the inlet of airflow

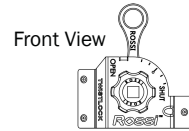

**45° Lateral Tee with Damper (LTD)**

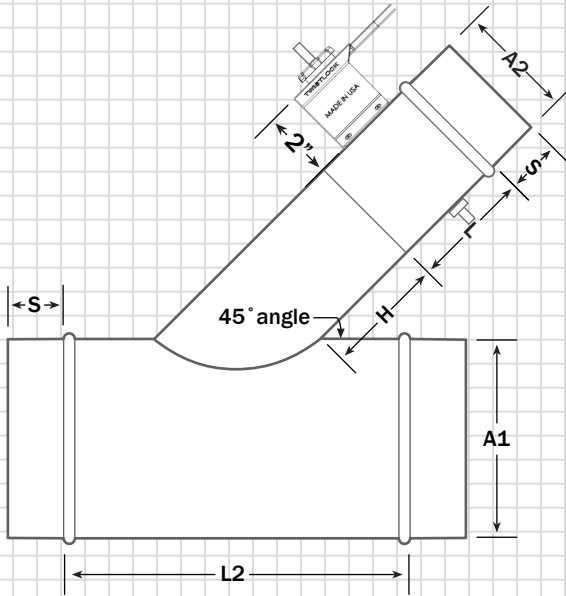

**Key (LTD)**

**Sizes Available for A1 & A2:**  
 4" - 10" (all sizes), 12" - 60" (even sizes only)  
**A1 is greater than or equal to A2**  
**S = 2"**  
**H = 4"**  
**L = 3.5"**  
**L2 = (A2 x 1.414) + 4"**

**Key (LRTD)**

**Sizes Available for A1, A2 & A3:**  
 4" - 10" (all sizes), 12" - 60" (even sizes only)  
**A1 is greater than or equal to A3**  
**A2 is less than A1**  
**S = 2"**  
**H = 4"**  
**L = 3.5"**  
**L2 = (A3 x 1.414) + 4"**  
**X = A1 - A2 (4" minimum)**

**Gauge**

4" - 24" = 24 ga.  
 26" - 36" = 22 ga.

**45° Lateral Reducing Tee with Damper (LRTD)**

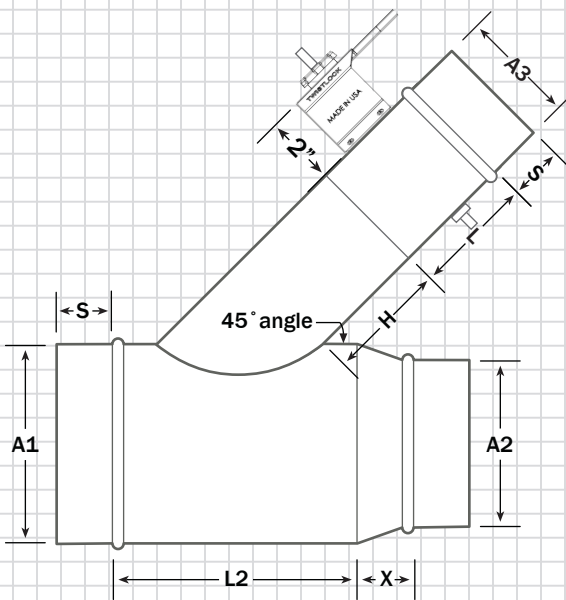

**Low-Leakage Dampers:**

- 2" Stand-off
- Nylon bushings
- Locking handle
- 3/8" Continuous square rod
- All dampers to be installed 90° from the inlet of airflow

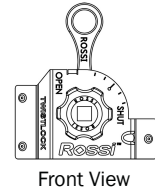

**90° Boot/Shoe Tap (BTP)**

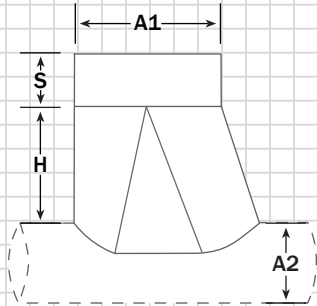

**Key (BTP)**

A1 = 4" - 10" (all sizes), 12" - 60" (even sizes only)  
 A2 is greater than or equal to A1  
 S = 2"  
 H = 5"

**Key (BTPD)**

A1 = 4" - 10" (all sizes), 12" - 60" (even sizes only)  
 A2 is greater than or equal to A1  
 S = 2"  
 L = 3.5"  
 H = 5"

**Gauge**

4" - 24" = 24 ga.  
 26" - 36" = 22 ga.

**90° Boot/Shoe Tap with Damper (BTPD)**

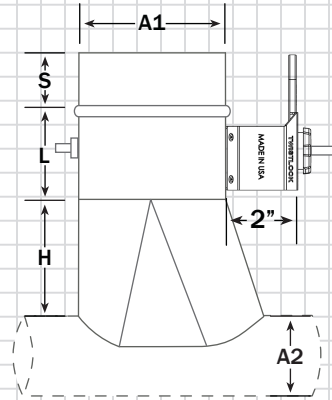

**Low-Leakage Dampers:**

- 2" Stand-off
- Nylon bushings
- Locking handle
- 3/8" Continuous square rod
- All dampers to be installed 90° from the inlet of airflow

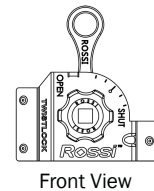

Front View

**Reducing Bull Head Tee (BRT)**

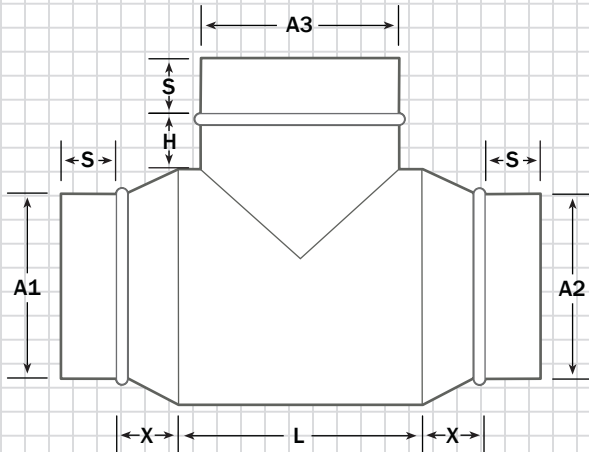

**Key (BRT)**

S = 2"  
 H = 2"  
 L = A3 + 4"  
 X = 4" minimum  
 A3 > A1 or A2

Order as: in, out, branch (A1, A2, A3)

**Gauge**

4" - 24" = 24 ga.  
 26" - 36" = 22 ga.

**Stamped Reducer (SR)**

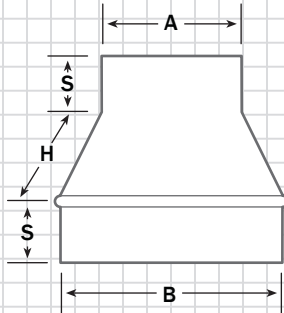

**Key (SR)**

- A = Small end diameter, S = 2"
- B = Large end diameter, S = 1.5"
- Galvanized 24 ga.
- Bead on large end is standard

**Dimensions (SR)**

B	A	H
6"	4"	1.75"
8"	6"	1.75"
10"	6"	2.75"
10"	8"	1.75"
12"	8"	2.75"
12"	10"	1.75"
14"	12"	1.75"

**Concentric Reducer (CR)**

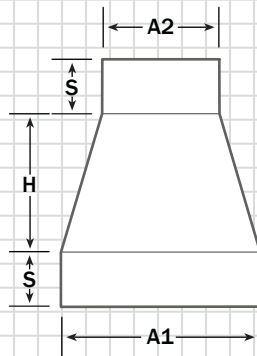

**Key (CR)**

- Sizes Available for A1 & A2:**  
 4" - 10" (all sizes), 12" - 60" (even sizes only)  
 S = 2"  
 H = 4" if the change in diameter (A1 - A2) is less than or equal to 6"  
 • If the change in diameter (A1 - A2) is greater than 6" then H = A1 - A2.  
 • Please specify any other length, if not the standard.

**Key (ER)**

- Sizes Available for A1 & A2:**  
 4" - 10" (all sizes), 12" - 60" (even sizes only)  
 S = 2"  
 H = (A1 - A2) x 2  
 • H minimum = 7- 3/4"  
 • Please specify any other length, if not the standard.

**Eccentric Reducer (ER)**

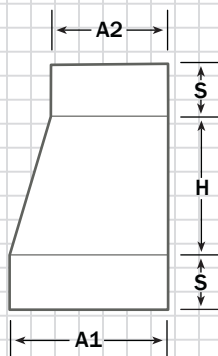

**Gauge**

- 4" - 24" = 24 ga.
- 26" - 36" = 22 ga.

**Conical Take-off (CTO)**

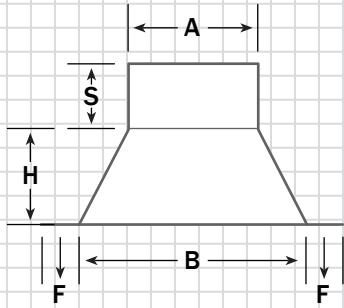

**Key (CTO)**

- A = 4" - 10" (all sizes), 12" - 60" (even sizes only)
- B = A + 1.5"
- S = 2.5"
- H = 3 - 3/4"
- F = 3/4" flange (.75")

**Key (CTOD)**

- A = 4" - 10" (all sizes), 12" - 60" (even sizes only)
- B = A + 1.5"
- S = 2"
- L = 3.5"
- H = 3 - 3/4"
- F = 3/4" flange (.75")

**Gauge**

- 4" - 24" = 24 ga.
- 26" - 36" = 22 ga.

**Conical Take-off with Damper (CTOD)**

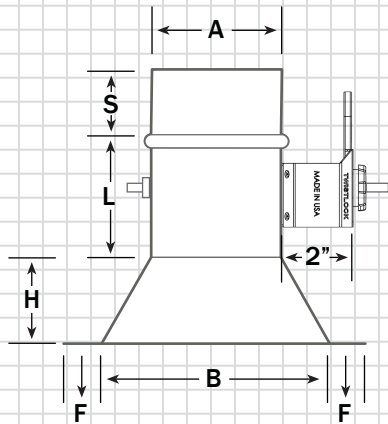

**Low-Leakage Dampers:**

- 2" Stand-off
- Nylon bushings
- Locking handle
- 3/8" Continuous square rod
- All dampers to be installed 90° from the inlet of airflow

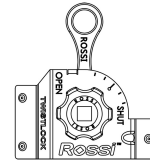

Front View

## Bellmouth Take-off with Bead (BTOB) No Bead (BTONB)

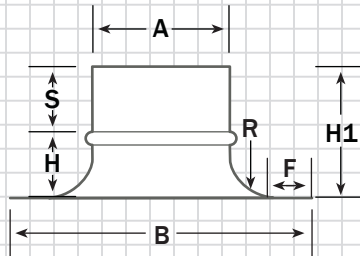

## Bellmouth Take-off with Damper (BTOBD)

4" - 12" BTOBD

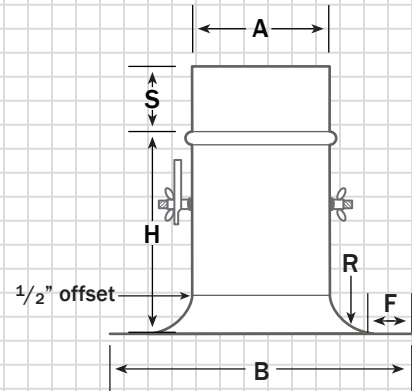

## Bellmouth Take-off with Heavy Duty 2" Stand-off (BTOD)

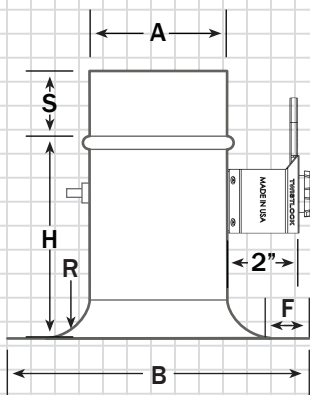

### Low-Leakage Dampers:

- 2" Stand-off
- Nylon bushings
- Locking handle
- 3/8" Continuous square rod
- All dampers to be installed 90° from the inlet of airflow

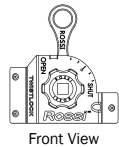

14" - 24" BTOBD

OPTION: 2" Shaft Extension  
Handle (BTOD2S)

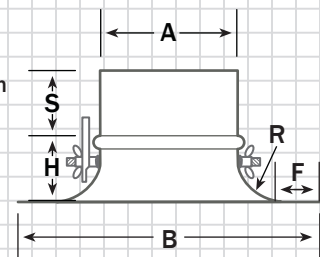
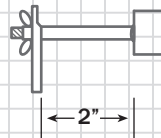

### Key

A = Diameter      H = Height  
R = Radius        H1 = BTONB height  
F = Flange length   S = Bead to end  
B = Width

### Materials Available

- Galvanized (4" - 12"), 24 ga., stamped
- Galvanized (14" - 24"), 20 ga., spun

### Options Available

- Sizes 4" - 24"
- 2" Stand-off, BTOD2S (see shaft extension handle drawing above)
- Peel & stick gasket is standard on BTOB (4" - 14")

### Dimensions

A	B	R	F	S (BTOB)	S (BTOBD, BTOD)	H1 (BTONB)	H (BTOB)	H (BTOBD, BTOD)
4"	7"	.394"	1"	1.25"	2"	2.5"	1.25"	6"
5"	8"	.472"	1"	1.25"	2"	2.5"	1.25"	6"
6"	9.25"	.787"	1"	1.5"	2"	2.875"	1.375"	6.25"
7"	10.5"	1.0"	1"	1.5"	2"	3.5"	2"	7"
8"	12"	1.0"	1"	1.5"	2"	3"	1.5"	6.5"
9"	13"	1.0"	1"	1.5"	2"	3.5"	2"	7"
10"	13.625"	1.0"	1"	1.5"	2"	3"	1.5"	6.5"
12"	15.625"	1.0"	1"	1.5"	2"	3.25"	1.75"	6.75"
14"	18"	2.0"	0.5"	1.5"	2"	6.5"	5"	10"
16"	20"	2.0"	0.5"	1.5"	2"	9"	7.5"	12.5"
18"	22"	2.0"	0.5"	2"	2"	9"	7"	12.5"
20"	24"	2.0"	0.5"	2"	2"	9"	7"	12.5"
22"	26"	2.0"	0.5"	2"	2"	9"	7"	12.5"
24"	28"	2.0"	0.5"	2"	2"	9"	7"	12.5"

**Coupling (CM/CF)**

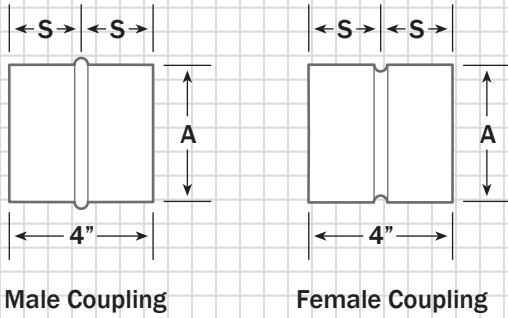

**Key (CM/CF)**

A = 3" - 60"  
S = 2"

Stitch welded construction

**Male Coupling** - For pipe, the ends are 1/8" undersize to fit inside spiral pipe. Bead is located at 2".

**Female Coupling** - For pipe, the ends are 1/8" oversize to fit over spiral pipe. Reverse bead is located at 2".

**Gauge**

4" - 24" = 24 ga.  
26" - 36" = 22 ga.

**End Plug (EP)**

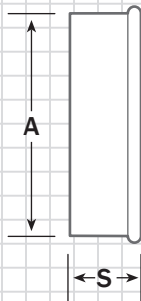

**Key (EP)**

A = Small end to fit in spiral pipe  
S = 2.75"

**Gauge**

4" - 24" = 24 ga.  
26" - 36" = 22 ga.

**Damper Section (D)**

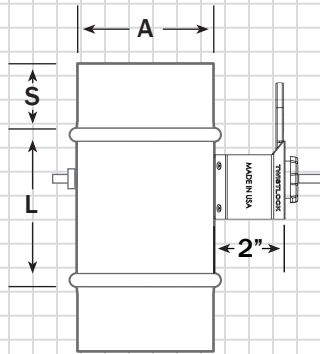

**Key (D)**

A = 4" - 10" (all sizes), 12" - 36" (even sizes only)  
 S = 2"  
 L = 4.75"

**Key (D1)**

A = 4" - 10" (all sizes), 12" - 36" (even sizes only)  
 S = 1.5"  
 L = 7.25"

**Gauge**

4" - 24" = 24 ga.  
 26" - 36" = 22 ga.

**Damper Section- Large End/Small End (D1)**

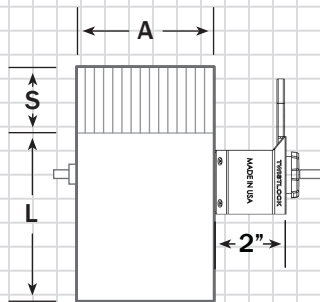

**Low-Leakage Dampers:**

- 2" Stand-off
- Nylon bushings
- Locking handle
- 3/8" Continuous square rod
- All dampers to be installed 90° from the inlet of airflow

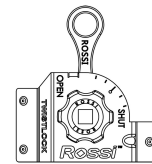

Front View

**Straight Take-off (STO)**

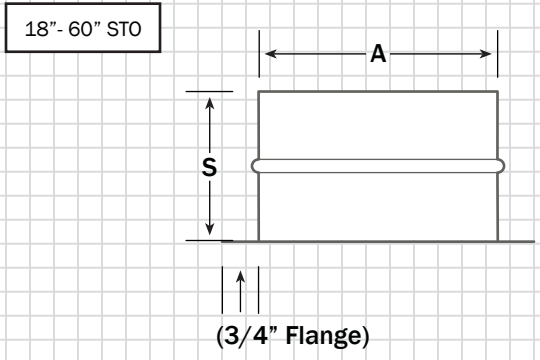
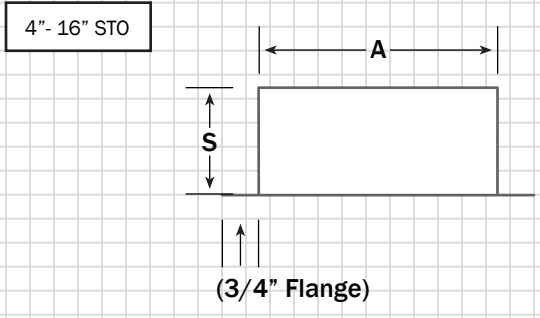

**Key (STO)**

A = 4" - 10" (all sizes), 12" - 60" (even sizes only)  
 S = 2 - 1/4" (4" - 16"), 3 - 1/4" (18" - 60")

**Key (STOD)**

A = 4" - 10" (all sizes), 12" - 60" (even sizes only)  
 S = 2"  
 L = 6"

**Gauge**

4" - 24" = 24 ga.  
 26" - 36" = 22 ga.

**Straight Take-off with Damper (STOD)**

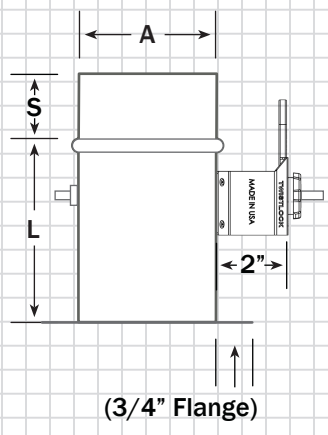

**Low-Leakage Dampers:**

- 2" Stand-off
- Nylon bushings
- Locking handle
- 3/8" Continuous square rod
- All dampers to be installed 90° from the inlet of airflow

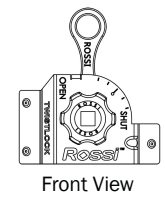

**Y Branch (Y)**

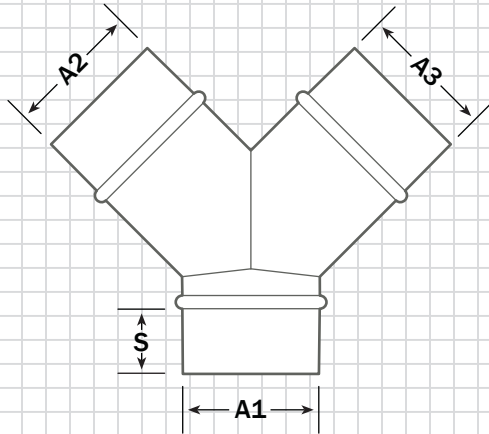

**Key (Y)**

Sizes Available for **A1, A2, & A3:**  
 4" - 10" (all sizes), 12" - 60" (even sizes only)  
**S = 2"**

**Key (RY)**

Sizes Available for **A1, A2, & A3:**  
 4" - 10" (all sizes), 12" - 60" (even sizes only)  
**A2 & A3 are less than A1**  
**S = 2"**

**Gauge**

4" - 24" = 24 ga.  
 26" - 36" = 22 ga.

**Reducing Y Branch (RY)**

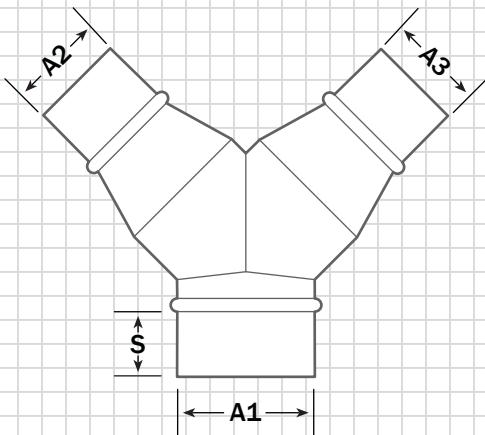

**Conical Cross (CROSC)**

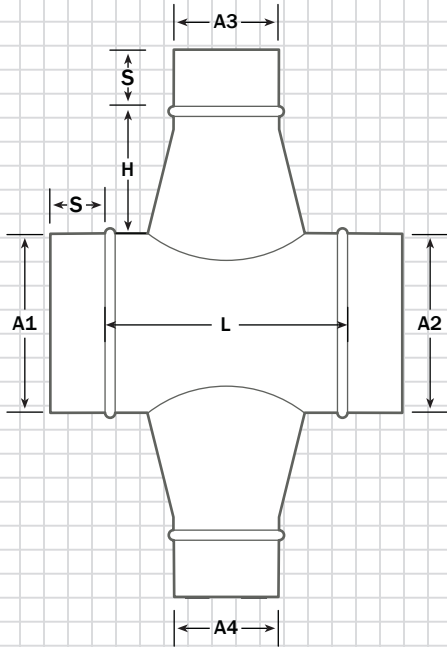

**Straight Cross (CROSS)**

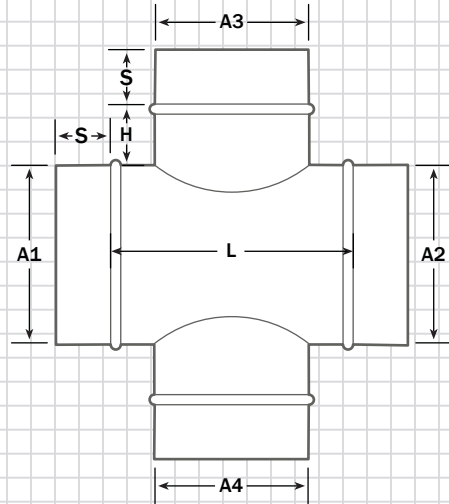

**45° Lateral Cross (CROSL)**

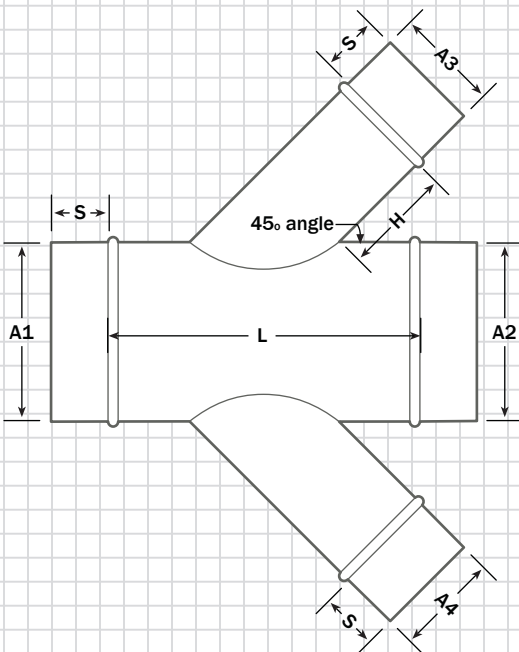

**Key (CROSC)**

**Sizes Available for A1, A2, A3 & A4:**  
 4" - 10" (all sizes), 12" - 60" (even sizes only)  
**A1 & A2** is greater than A3 & A4 (= 2" min.)  
**A3** is greater than or equal to **A4**  
**S** = 2"  
**H** = 5"  
**L** = A3 + 4"

**Key (CROSS)**

**Sizes Available for A1, A2, A3 & A4:**  
 4" - 10" (all sizes), 12" - 60" (even sizes only)  
**A1 & A2** is greater than or equal to **A3 & A4**  
**A3** is greater than or equal to **A4**  
**S** = 2"  
**H** = 2"  
**L** = A3 + 4"

**Key (CROSL)**

**Sizes Available for A1, A2, A3 & A4:**  
 4" - 10" (all sizes), 12" - 60" (even sizes only)  
**A1 & A2** is greater than or equal to **A3 & A4**  
**A3** is greater than or equal to **A4**  
**S** = 2"  
**H** = 4"  
**L** = (A3 x 1.414) + 4"

**Gauge**

4" - 24" = 24 ga.  
 26" - 36" = 22 ga.

**Conical Cross with Damper (CROSCD)**

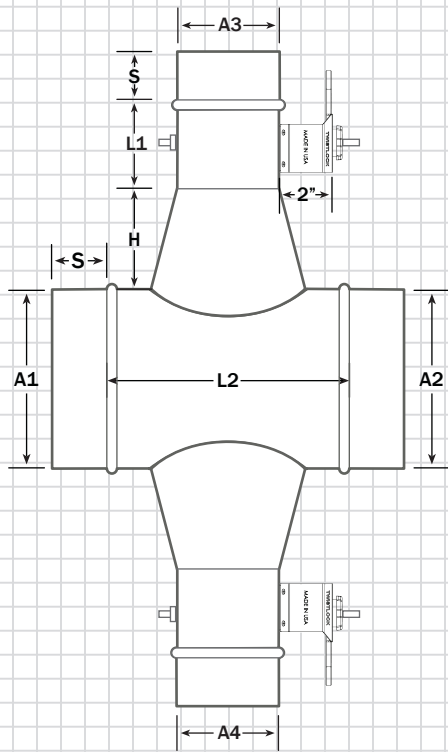

**Straight Cross with Damper (CROSSD)**

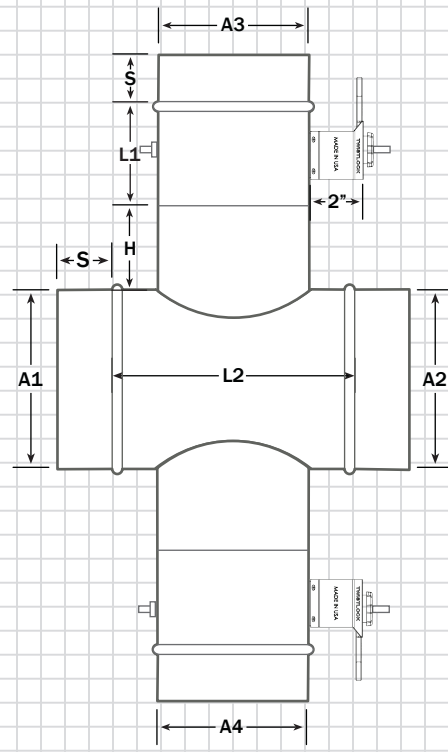

**Key (CROSCD)**

**Sizes Available for A1, A2, A3 & A4:**  
 4" - 10" (all sizes), 12" - 60" (even sizes only)  
 A1 & A2 is greater than A3 & A4 (= 2" min.)  
 A3 is greater than or equal to A4  
 S = 2"  
 H = 5"  
 L1 = 3.5", L2 = A3 + 4"

**Key (CROSSD)**

**Sizes Available for A1, A2, A3 & A4:**  
 4" - 10" (all sizes), 12" - 60" (even sizes only)  
 A1 & A2 is greater than or equal to A3 & A4  
 A3 is greater than or equal to A4  
 S = 2"  
 H = 4"  
 L1 = 3.5", L2 = A3 + 4"

**Key (CROSLD)**

**Sizes Available for A1, A2, A3 & A4:**  
 4" - 10" (all sizes), 12" - 60" (even sizes only)  
 A1 & A2 is greater than or equal to A3 & A4  
 A3 is greater than or equal to A4  
 S = 2"  
 H = 4"  
 L1 = 3.5", L2 = (A3 x 1.414) + 4"

**Gauge**

4" - 24" = 24 ga.  
 26" - 36" = 22 ga.

**45° Lateral Cross with Damper (CROSLD)**

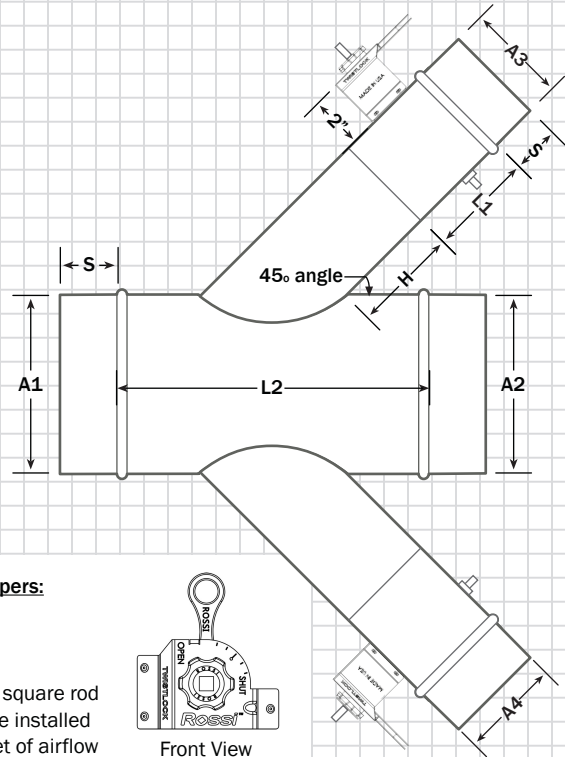

**Low-Leakage Dampers:**

- 2" Stand-off
- Nylon bushings
- Locking handle
- 3/8" Continuous square rod
- All dampers to be installed 90° from the inlet of airflow

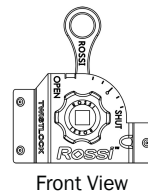

**Reducing Conical Cross (RCC)**

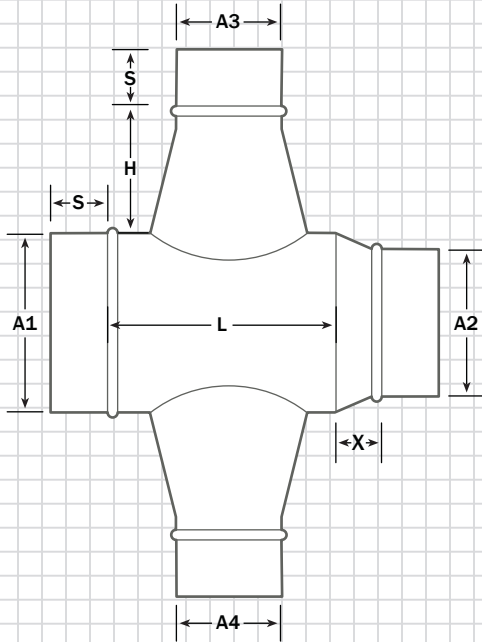

**Reducing Straight Cross (RCS)**

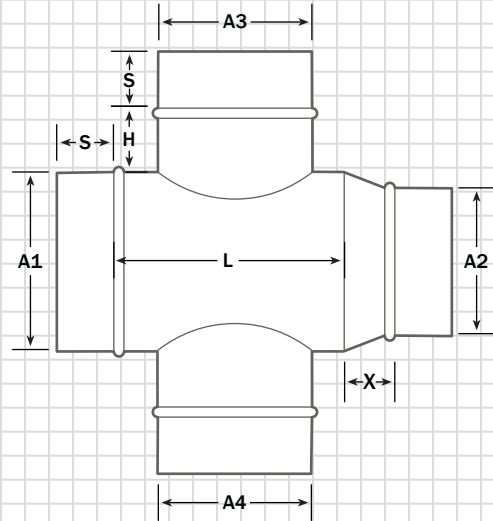

**Key (All)**

Sizes available for A1, A2, A3 & A4:  
 4"-10" (all sizes), 12"-60" (even sizes only)  
 A1 is greater than A3 & A4 (= 2" min.)  
 A2 is less than A1  
 A3 is greater than or equal to A4  
 S = 2"  
 X = A1 - A2 (4" minimum)

**Key (RCC)**

L = A3 + 4"  
 H = 5"

**Key (RCS)**

L = A3 + 4"  
 H = 2"

**Key (RCL)**

L = (A3 x 1.414) + 4"  
 H = 4"

**Gauge**

4" - 24" = 24 ga.  
 26" - 36" = 22 ga.

**Reducing 45° Lateral Cross (RCL)**

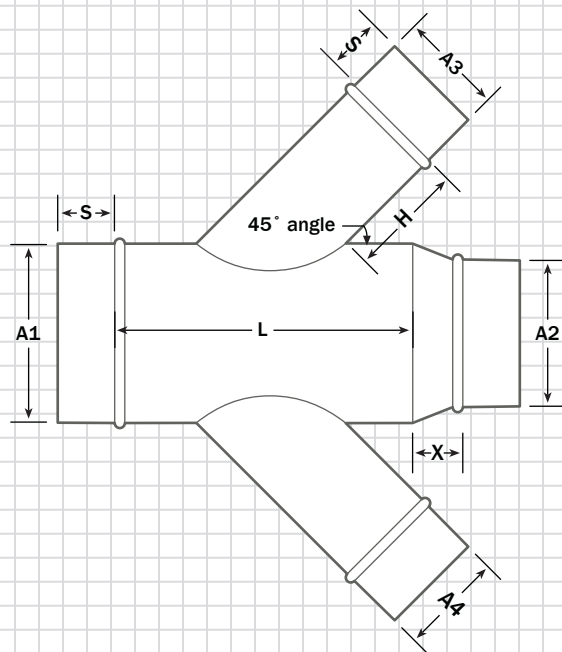

**Reducing Conical Cross with Damper (RCCD)**

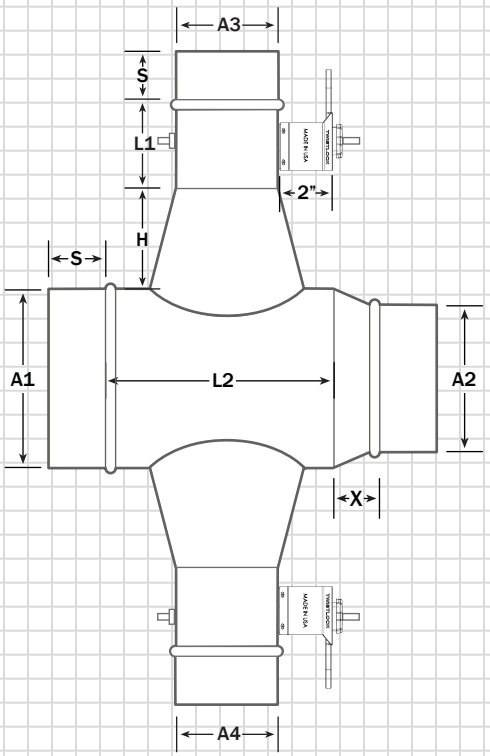

**Reducing Straight Cross with Damper (RCSD)**

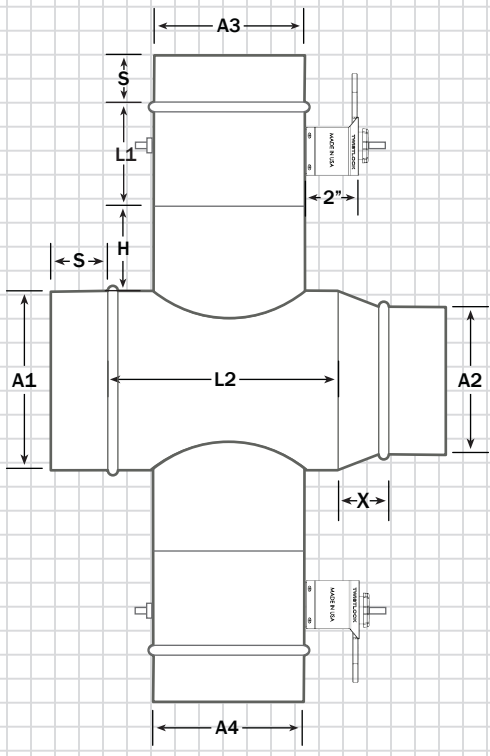

<b>Key (All)</b>
Sizes available for A1, A2, A3 & A4: 4"-10" (all sizes), 12"-60" (even sizes only) A1 is greater than A3 & A4 (= 2" min.) A2 is less than A1 A3 is greater than or equal to A4 S = 2" X = A1 - A2 (4" minimum)
<b>Key (RCCD)</b>
L1 = 3.5" L2 = A3 + 4" H = 5"
<b>Key (RCSD)</b>
L1 = 3.5" L2 = A3 + 4" H = 2"
<b>Key (RCLD)</b>
L1 = 3.5" L2 = (A3 x 1.414) + 4" H = 4"
<b>Gauge</b>
4"- 24" = 24 ga. 26"- 36" = 22 ga.

**Reducing 45° Lateral Cross with Damper (RCLD)**

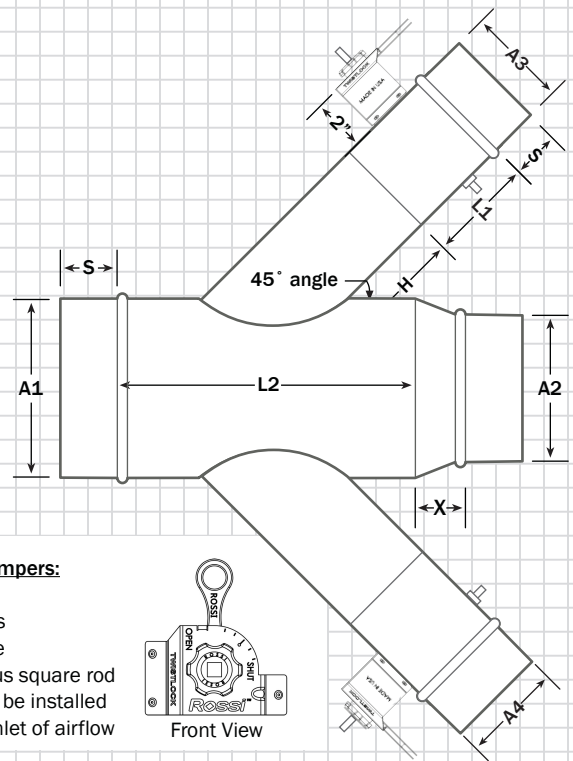

- Low-Leakage Dampers:**
- 2" Stand-off
  - Nylon bushings
  - Locking handle
  - 3/8" Continuous square rod
  - All dampers to be installed 90° from the inlet of airflow

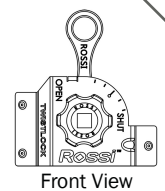

**High Efficiency Take-off  
No Damper (HET)**

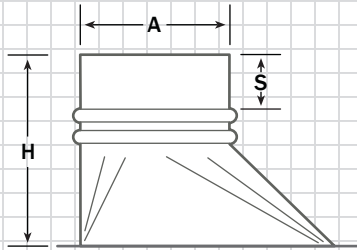

**Dimensions (HET)**

A	S	Rectangle Opening	H
4"	2"	8" x 6"	9.5"
5"	2"	10" x 6"	8.25"
6"	2"	12" x 6"	8.25"
7"	2"	12" x 6"	9.25"
8"	2"	12" x 6"	8"
9"	2"	15" x 6"	10.25"
10"	2"	16" x 6.75"	9.5"
12"	2"	18" x 8.5"	9.75"
14"	2"	20" x 9.5"	10.25"
16"	2"	24" x 12"	11.5"

**High Efficiency Take-off  
Standard Damper Hardware (HETD)**

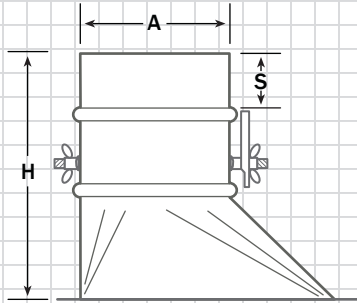

**Dimensions  
(HETD/HETD2S/HETDHD)**

A	S	Rectangle Opening	H
4"	2"	8" x 6"	12.5"
5"	2"	10" x 6"	11"
6"	2"	12" x 6"	11.5"
7"	2"	12" x 6"	12.5"
8"	2"	12" x 6"	11.25"
9"	2"	15" x 6"	13.25"
10"	2"	16" x 6.75"	13"
12"	2"	18" x 8.5"	13"
14"	2"	20" x 9.5"	14"
16"	2"	24" x 12"	15"

**High Efficiency Take-off  
Standard Damper Hardware with  
2" Extension (HETD2S)**

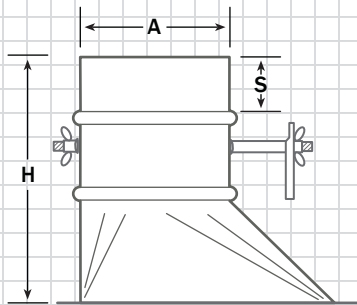

**High Efficiency Take-off  
Heavy Duty 2" Stand-off (HETDHD)**

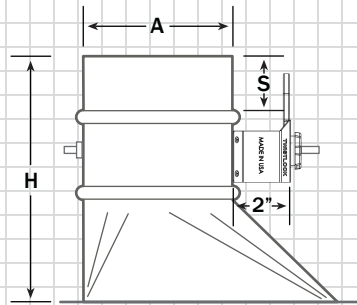

**Materials**  
Galvanized 24 gauge

**Features**

- Continuous weld on longitudinal seam for zero air leakage at 2" WG static pressure
- 1" wide flange with peel and stick gasket and pre-drilled holes for ease of installation

- Low-Leakage Dampers:**
- 2" Stand-off
  - Nylon bushings
  - Locking handle
  - 3/8" Continuous square rod
  - All dampers to be installed 90° from the inlet of airflow

