

Gasket Straight Tap (GST)

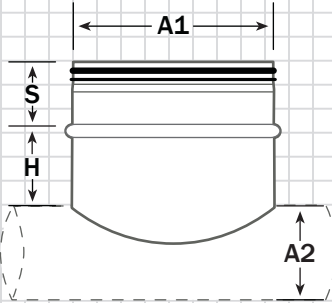

Gasket 90° Straight Tap with Damper (GSTD)

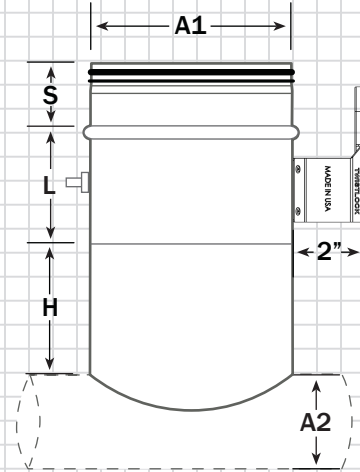

Gasket 90° Tee (GT)

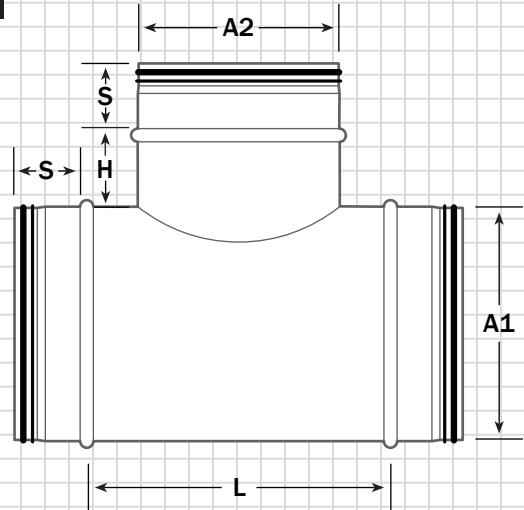

Key (GST)

Sizes Available for A1:
 4"- 10" (all sizes), 12"- 60" (even sizes only)
A2 is greater than or equal to **A1**
S = 2"
H = 2"

Key (GSTD)

Sizes Available for A1:
 4"- 10" (all sizes), 12"- 60" (even sizes only)
A2 is greater than **A1**
S = 2"
H = 4"
L = 3.5"

Key (GT)

Sizes Available for A1 & A2:
 4"- 10" (all sizes), 12"- 60" (even sizes only)
A1 is greater than or equal to **A2**
S = 2"
H = 2"
L = **A2** + 4"

Key (GSRT)

Sizes Available for A1, A2 & A3:
 4"- 10" (all sizes), 12"- 60" (even sizes only)
A1 is greater than **A3**, **A2** is less than **A1**
S = 2"
H = 2"
L = **A3** + 4"
X = **A1** - **A2** (4" minimum)

Gauge

4"- 24" = 24 ga.
 26"- 36" = 22 ga.

Gasket 90° Straight Reducing Tee (GSRT)

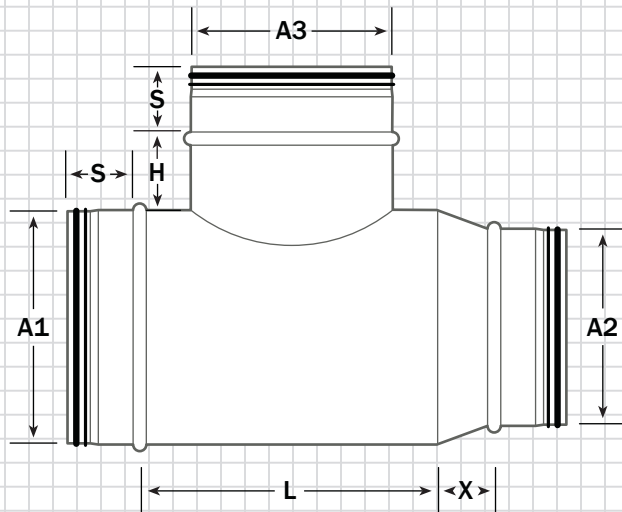

Low-Leakage Dampers:

- 2" Stand-off
- Nylon bushings
- Locking handle
- 3/8" Continuous square rod
- All dampers to be installed 90° from the inlet of airflow

