

# The EDGE® – Product Specifications

## LoPro High Efficiency Take-off

Our LoPro High Efficiency Take-off is fabricated from 24 gauge G90 galvanized steel. This product is made with a low profile design to save room when installing on flat duct and to capture maximum air flow. The connection is The EDGE® self-sealing gasket which has been tested in accordance with SMACNA's Air Duct Leakage Test Manual and meets SMACNA Class 3 leakage standards. Products come standard with a peel-and-stick on the base.

### (GLPHET) No Damper

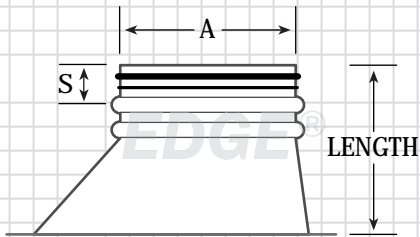

### Dimensions

(A)	(S)	Inside Opening	Overall Length
4"	2"	4" x 6"	7.5"
5"	2"	5" x 7"	7.5"
6"	2"	5" x 8"	6.5"
7"	2"	6" x 9"	7"
8"	2"	7" x 10"	7"
9"	2"	8" x 11"	7"
10"	2"	9" x 12"	7"
12"	2"	11" x 14"	7"
14"	2"	13" x 16"	7"
16"	2"	14" x 22"	11"

### (GLPHETDHD) Heavy Duty 2" Stand-off Locking Balancer Damper

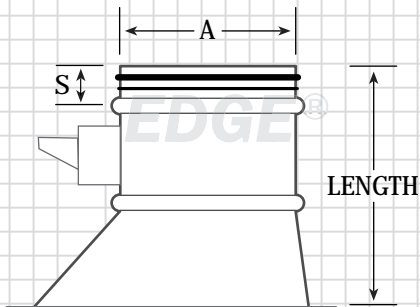

### Dimensions

(A)	(S)	Inside Opening	Overall Length
4"	2"	4" x 6"	10"
5"	2"	5" x 7"	10"
6"	2"	5" x 8"	7"
7"	2"	6" x 9"	9"
8"	2"	7" x 10"	9"
9"	2"	8" x 11"	9"
10"	2"	9" x 12"	9"
12"	2"	11" x 14"	9"
14"	2"	13" x 16"	9.5"
16"	2"	14" x 22"	13.25"