

Stamped Fittings® - Product Specifications

Bellmouth Take-off with Damper (BTOD)

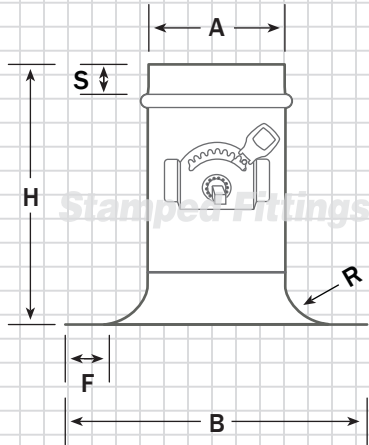

Features

- 24 Gauge galvanized body (4" - 16")
- 22 Gauge galvanized body (18" - 36")

Low-Leakage Dampers

- 2" Stand-off (20 ga.)
- Nylon bushings
- Locking handle for adjustment of damper - ease of balancing
- 3/8" Continuous square rod through damper

Dimensions

(A)	(B)	(R)	(F)	(H)	(S)
4"	7"	.394"	1"	8"	1.5"
5"	8"	.472"	1"	8"	1.5"
6"	9.25"	.787"	1"	8.25"	1.5"
7"	10.5"	1.0"	1"	9.125"	1.5"
8"	12"	1.0"	1"	8.5"	1.5"
9"	13"	1.0"	1"	9.125"	1.5"
10"	13.625"	1.0"	1"	8.5"	1.5"
12"	15.625"	1.0"	1"	8.5"	1.5"
14"	12.125"	2.0"	1"	17"	2"
16"	14.125"	2.0"	1.5"	20"	2"
18"	14.125"	2.0"	1.5"	22"	2"
20"	14.125"	2.0"	1.5"	24"	2"
22"	14.125"	2.0"	1.5"	26"	2"
24"	14.125"	2.0"	1.5"	28"	2"
26"	14.125"	2.0"	1.5"	30"	2"
28"	14.125"	2.0"	1.5"	32"	2"
30"	14.125"	2.0"	1.5"	34"	2"
32"	14.125"	2.0"	1.5"	36"	2"
34"	14.125"	2.0"	1.5"	38"	2"
36"	14.125"	2.0"	1.5"	40"	2"

Key

A = Diameter B = Overall width
R = Radius H = Overall height
F = Flange length S = Bead to end

Materials Available

- Galvanized (4" - 12"), 24 ga., stamped
- Galvanized (14" - 36"), 20 ga., spun

Options Available

- Sizes 4" - 36"