



The EDGE[®]

Self-Sealing Round Duct System



The EDGE[®] – Features, Benefits & Materials

The EDGE[®] System will eliminate the sealing of all connections in your spiral pipe system. This system will not only provide a labor savings for the installer, it is a high efficient duct system and also great for exposed systems.

FEATURES

- 1 All fittings will have a factory installed EPDM gasket, which has an operating temperature rating of -20°F to 212°F.
- 1 The smoke and flame spread rating is 0/0.
- 1 The gasket construction is of a black EPDM base with a wiper for machine application and a green EPDM hollow seal that will act as the sealing section.
- 1 The gasket is attached to the fitting with a 180° hemmed edge that will hold the gasket in place, as shown in the diagrams to the right.
- 1 The connections are secured with self-tapping sheet metal screws per SMACNA standards.
- 1 The EDGE[®] System allows for substantial space for insertion of the screws, because the gasket is located on the leading EDGE of the fitting. (NOTE: The use of sheet metal screws with a rubber gasket would insure that all screw holes are sealed as well.
- 1 The EDGE[®] System has been tested in accordance to SMACNA's Air Duct Leakage Test Manual and meets SMACNA Class 3 leakage standards.

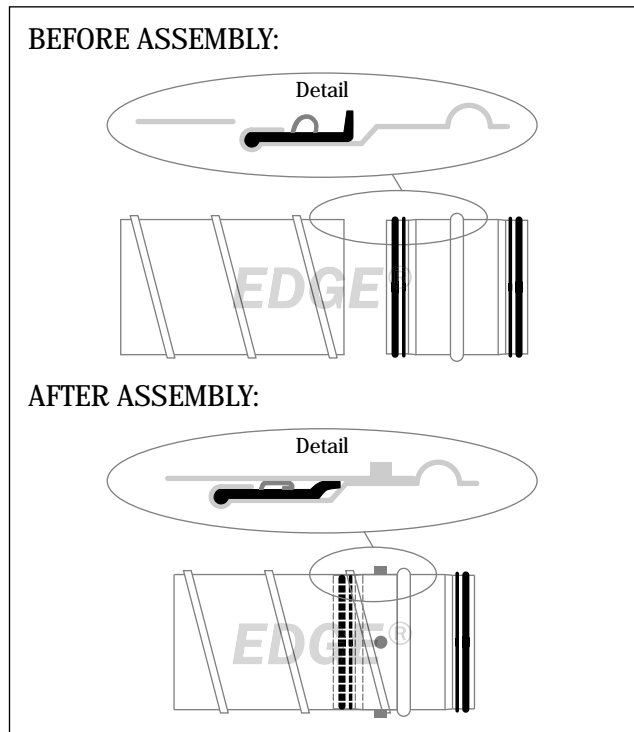

BENEFITS

- 1 Stronger fitting
- 1 Eliminates sharp edge
- 1 Consistent diameter
- 1 Factory installed resulting in a cost savings
- 1 The EDGE[®] gasket is treated with anti-friction coating for easy installation.

The EDGE[®] – Fittings & Materials

Fittings: 4" - 10" (all sizes), 12" - 60" (even sizes only)

Materials: Galvanized, Galvaneal, Stainless Steel Type 304 & 316, Aluminum.

All fittings will be fabricated, except for Galvanized Stamped Fittings[®] listed below:

Elbows	4" - 12" = Stamped/Stitch Welded
Reducers	4" - 24" = Spun
Bellmouths	4" - 12" = Stamped 14" - 36" = Spun
90° Tee	4" - 12" = Fabricated body with Stamped Saddle Tap
90° Tap	4" - 12" = Stamped
All Other Fittings	Any fitting can be fabricated with gasket attached. All products will be fabricated per SMACNA standards and gauges. All fabricated fittings conform to SPIDA dimensional data.

The EDGE® – Construction

CONSTRUCTION (GAUGE):

- 1 All duct and fittings are made per SMACNA's Duct Construction Standards (+10" W.G.).
- 1 Stamped Fittings are all 22 or 24 gauge. Spun Fittings are all 20 gauge.
- 1 The following table shows diameter and gauges:

Diameter	Spiral Duct	Fabricated Fittings
4" - 24"	26 ga.	24 ga.
26" - 36"	24 ga.	22 ga.
38" - 60"	22 ga.	Please Specify

Stamped Fittings®	4"	5"	6"	7"	8"	9"	10"	12"	14" - 36"
GDSE	24 ga.	22 ga.	22 ga.	22 ga.	22 ga.	22 ga.	22 ga.	22 ga.	N/A
GDSE1	24 ga.	24 ga.	24 ga.	24 ga.	24 ga.	24 ga.	24 ga.	22 ga.	N/A
GDST	24 ga.	24 ga.	24 ga.	24 ga.	24 ga.	24 ga.	24 ga.	24 ga.	N/A
GBTO - stamped	24 ga.	24 ga.	24 ga.	24 ga.	24 ga.	24 ga.	24 ga.	24 ga.	N/A
GBTO - spun	N/A	N/A	N/A	N/A	N/A	N/A	N/A	N/A	20 ga.
GSPR - spun	20 ga.	20 ga.	20 ga.	20 ga.	20 ga.	20 ga.	20 ga.	20 ga.	20 ga.

CONSTRUCTION (PIPE):

- 1 Spiral pipe
- 1 Calibration of spiral is required by The EDGE® System manufacturer, Stamped Fittings Inc.

CONSTRUCTION (FITTINGS):

All EDGE® fittings, 4"– 60", will have a factory installed gasket that is attached to the fitting with a 180° hemmed edge for strength, rigidity and maintaining proper tolerances.

CONSTRUCTION (GASKET):

- 1 The EDGE® gasket consists of a two-part EPDM rubber sealing material.
- 1 The base EPDM (black material) is classified according to ASTM D2000-86 M3BA 810 B13 C12 F17.
- 1 The sealing EPDM (green material) is classified according to ASTM D2000-86 M8BA 507 B13 C12.
- 1 The operating temperature is -20°F to 212°F.
- 1 The smoke and flame spread is in accordance to ASTM E-84-91A.

PRESSURE CLASS:

- 1 The EDGE® System has been tested and meets the requirements of SMACNA's Leakage Class 3.

JOINT CONNECTIONS:

- 1 All fittings are manufactured to slip fit into spiral duct. Any fitting to fitting connection can use a fitting coupling.

The EDGE® – Installation Instructions

The EDGE® System fittings are made to fit tight, assuring a proper seal. Care should be taken when handling these fittings as damage could result in an improper fit and a difficult installation process.



WHEN INSTALLING:

1. Place the hemmed EDGE of the fitting in the spiral pipe then apply pressure and the fitting will slip into place, stopping at the bead/pipe stop.
2. Placement of the fastening screws should be opposite from one another, evenly spaced around the circumference (see diagram). Screws should be placed approximately 1/2" from the bead in order to avoid damaging The EDGE® gasket. In the event of incorrect installation, holes caused by the screws must be sealed before reassembly.
3. Quantities and sizes to be used are listed in the table below.

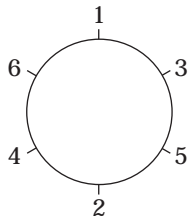

Spiral Duct Diameter	Screw Diameter	Quantity
3" - 5"	1/8"	2
6" - 10"	1/8"	3
12" - 24"	1/8"	4
26" - 36"	1/8"	6

4. Always start the first fastener at the largest radial gap between fitting and duct. Be sure to achieve even distribution around the circumference.

ASSEMBLY:

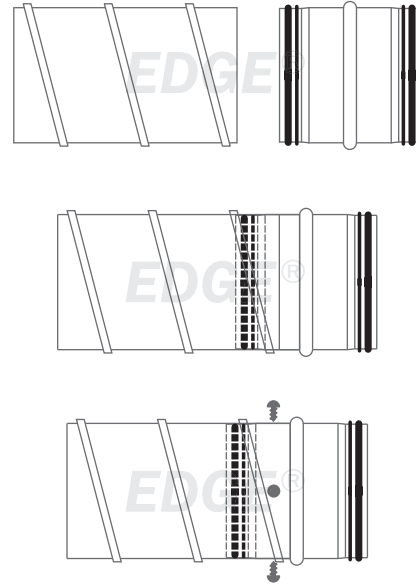

Patent Pending US 2006-0006610A1

The EDGE® – Products

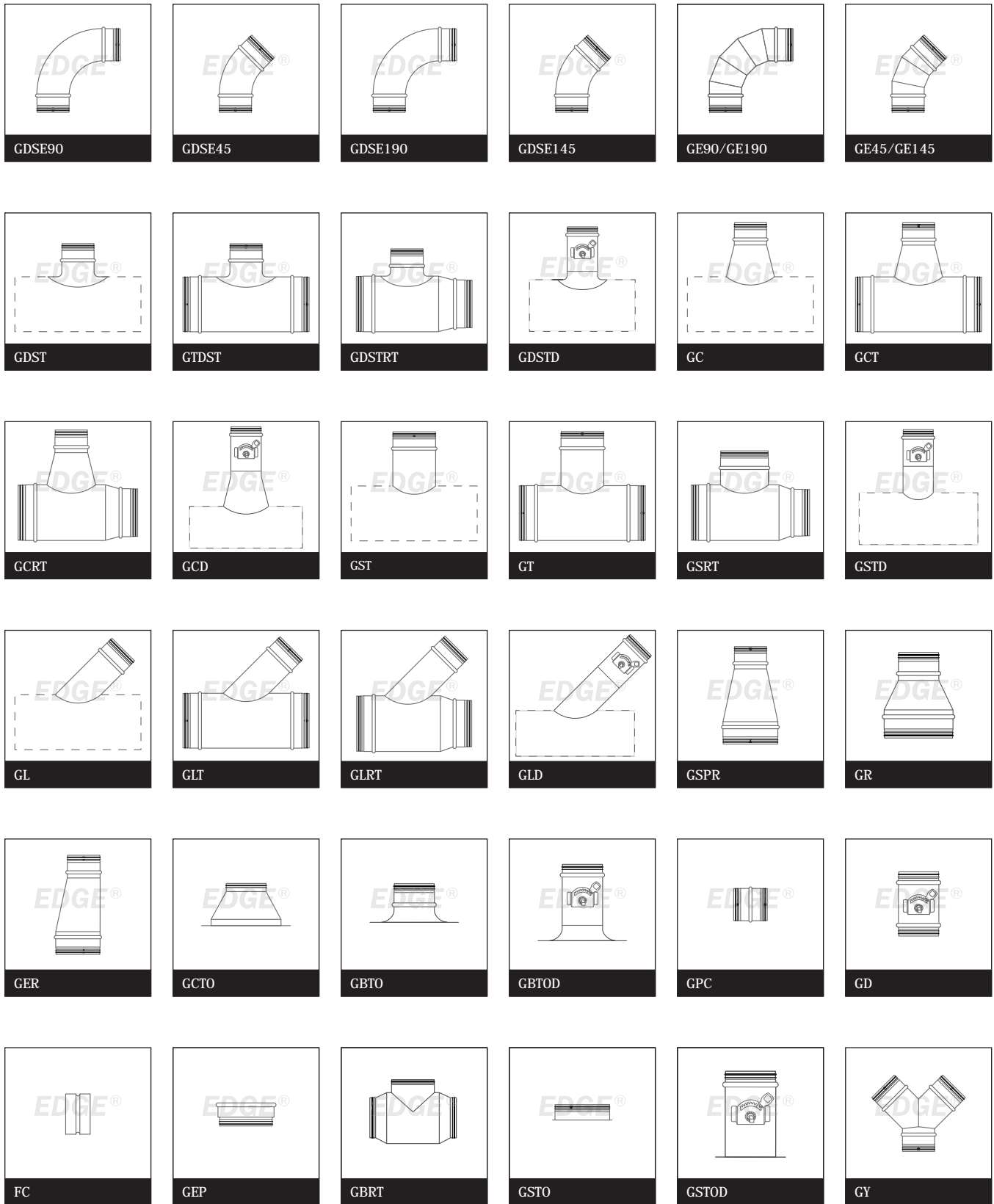

All of The EDGE® System products in this catalog are manufactured & distributed by Stamped Fittings® Inc.

The EDGE® – Products

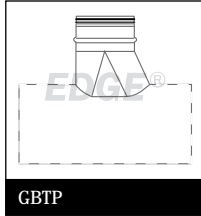
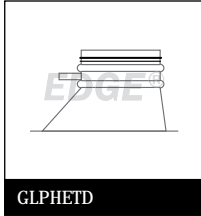
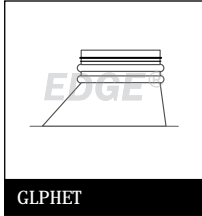
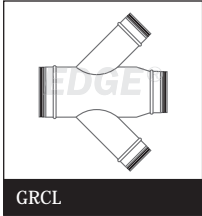
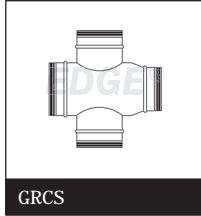
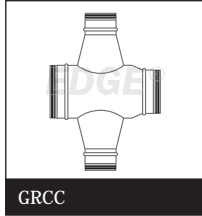
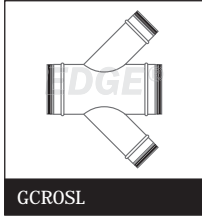
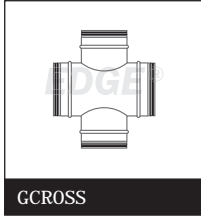
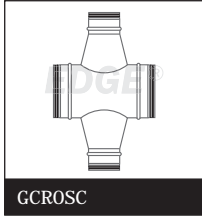

All of The EDGE® System products in this catalog are manufactured & distributed by Stamped Fittings® Inc.

Revised January 2019